

# **PARTS CATALOGUE**

**YZ426FM (5JG1) U.S.A.**  
**YZ426F (5JG2) EUROPE**  
**YZ426F (5JG3) JAPAN**  
**YZ426FM (5JG4) CANADA, OCEANIA, S.AFRICA**

---

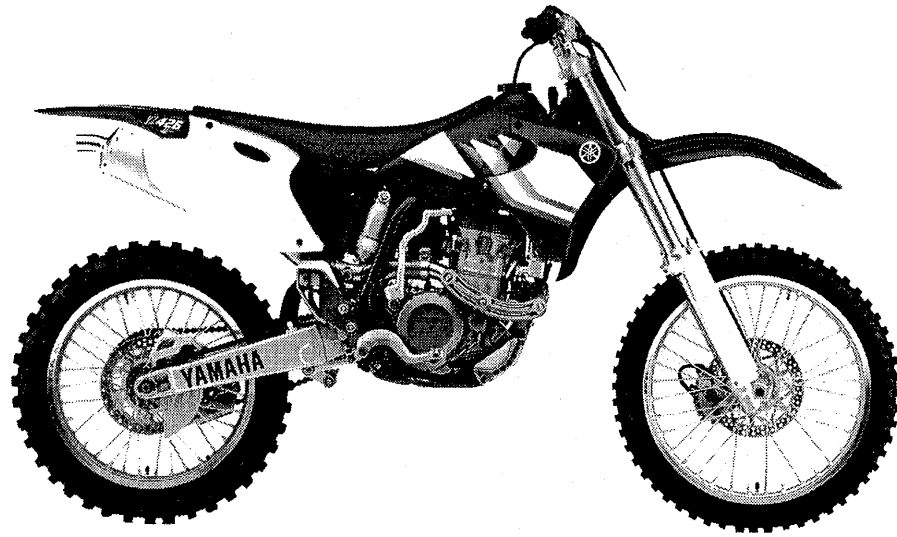

A3

# FOREWORD

This Parts Catalogue is related to the parts for the model(s) in the below frame. When you are ordering replacement parts, please refer to this Parts Catalogue and quote both part numbers and part names correctly.

YZ426FM(5JG1/5JG4)YZ426F(5JG2/5JG3)

1. Modifications or additions which have been made after issue of the Parts Catalogue will be announced in the Yamaha Parts News.  
It is advisable that you make necessary corrections to the Parts Catalogue according to the Yamaha Parts News.

## 2. Abbreviations

The Following abbreviations are used in this Parts Catalogue.

"UR" Use specified parts number.

"UN" Use as many as needed.

"AP" Alternate Parts

"LM" Local Made (Parts need to be ordered locally)

"F#" Frame No. (Applicable machine No.)

3. Parts, which are to be supplied in an assembly, are listed with a dot(.) in front of the part name as shown below.

### EXAMPLE

CARBURETOR ASSY

.JET, PILOT

.NOZZLE, MAIN

4. Number of component for assembly

The numeral appearing to the right of each component part indicates the quantity of parts for each assembly unit.

### EXAMPLE

PART NO.	DESCRIPTION	Q'TY	REMARKS
2F5-83310-60	FRONT FLASHER LIGHT ASSY	2	
115-83311-60	.BULB (6V-18W)	1	
1M1-83309-60	.REFLECTOR	1	

5. Applicable colors of graphics are represented in the "REMARKS" as shown below.

PART NO.	DESCRIPTION	Q'TY	REMARKS
2N4-24110-00-X5	.FUEL TANK COMP.	2	MXR
3J1-24240-10	.GRAPHIC, FUEL TANK	1	for MXR

6. Applicable Serial No.

Engine Serial No.

Frame Serial No.

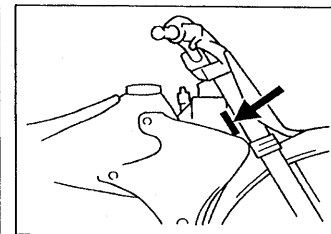
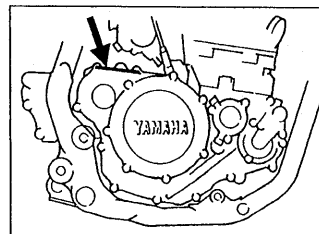

7. Note that the illustrations for reference in funding parts numbers, not to be used for assembling. When assembling, please use the applicable service manual.
8. The asterisk (\*) before a reference number indicates modification items after the first edition.

# MODEL LABEL

(1) A label called "Model Label" is affixed in the location as indicated in (3) below.  
When using this parts catalogue, please be sure to cross-refer the "model code – production code No." in the catalogue to the "model code – production code No." indicated on the Model Label affixed onto the product concerned.

(2) "Model Label" Indication

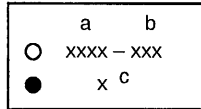

a: Model Type Code  
b: Production Code No.  
c: Colouring Type

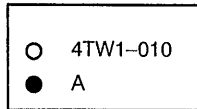

(3) Model Label Affixing Location

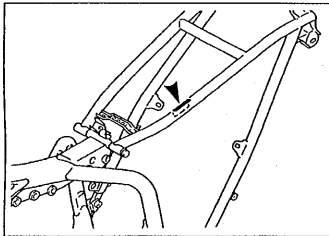

(4) Model Code – Production Code Number of Model Listed in This Parts Catalog

Model Code	Production Code No.	Country (destination)	Model Code	Production Code No.	Country (destination)
5JG1	010	U.S.A	5JG4	030	NEWZEALAND
5JG2	010	FRANCE		040	S.AFRICA
	020	BELGIUM			
	030	GERMANY			
	040	SPAIN			
	050	FINLAND			
		IRELAND			
	060	ENGLAND			
	070	GREECE			
	080	ITALY			
	090	PORTUGAL			
100	SWEDEN				
5JG3	010	JAPAN			
5JG4	010	AUSTRALIA			
	020	CANADA			

(5) Colouring Information

Colouring type code	Colour code	Colour Name	Abbreviation
A	0583	DEEP PURPLISH BLUE SOLID E	DPBSE

# CONTENTS

## ENGINE

CYLINDER .....	B2
CRANKSHAFT. PISTON .....	B4
VALVE .....	B5
CAMSHAFT. CHAIN .....	B7
WATER PUMP .....	B8
RADIATOR. HOSE .....	B9
OIL PUMP .....	B10
OIL CLEANER .....	B12
INTAKE .....	B13
CARBURETOR .....	B14
EXHAUST .....	C4
CRANKCASE .....	C5
CRANKCASE COVER 1 .....	C6
STARTER .....	C7
CLUTCH .....	C8
TRANSMISSION .....	C9
SHIFT CAM. FORK .....	C11
SHIFT SHAFT .....	C12

## CHASSIS

FRAME .....	C13
FENDER .....	C15
SIDE COVER .....	D2
REAR ARM .....	D3
REAR SUSPENSION .....	D5
STEERING .....	D7
FRONT FORK .....	D8
FUEL TANK .....	D11
SEAT .....	D12
FRONT WHEEL .....	D13
FRONT BRAKE CALIPER .....	D14
REAR WHEEL .....	D15

REAR BRAKE CALIPER .....	E3
STEERING HANDLE. CABLE .....	E4
FRONT MASTER CYLINDER .....	E5
STAND. FOOTREST .....	E6
REAR MASTER CYLINDER .....	E7
GENERATOR .....	E8
HANDLE SWITCH. LEVER .....	E9
ELECTRICAL 1 .....	E10
ALTERNATE (CHASSIS) .....	E11

## INDEX

NUMERICAL INDEX .....	M1
-----------------------	----

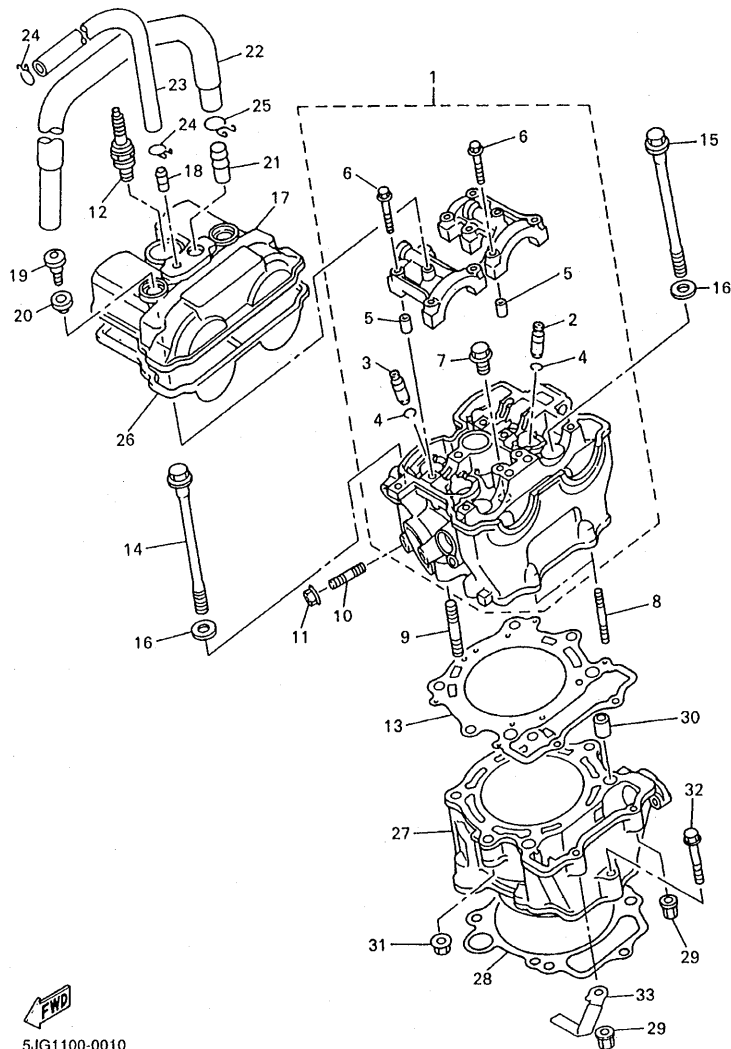

5JG1100-0010

FIG. 1 CYLINDER

REF. NO.	PART NO.	DESCRIPTION	5JG1	5JG2	5JG3	5JG4	REMARKS
1	5JG-11102-00	CYLINDER HEAD ASSY	1	1	1	1	
2	5BE-11133-10	.GUIDE, INTAKE VALVE	3	3	3	3	
3	5BE-11134-10	.GUIDE, EXHAUST VALVE	2	2	2	2	
4	93440-10153	.CIRCLIP	5	5	5	5	
5	91808-16023	.PIN, DOWEL	4	4	4	4	
6	90105-067A6	.BOLT, WASHER BASED	10	10	10	10	
7	90340-12112	.PLUG, STRAIGHT SCREW	1	1	1	1	
8	95617-06635	BOLT, STUD	2	2	2	2	
9	95617-08635	BOLT, STUD	2	2	2	2	
10	95617-08620	BOLT, STUD	1	1	1	1	
11	95707-08500	NUT, FLANGE	1	1	1	1	
12	94701-00330	PLUG, SPARK (NGK-R CR8E)	1	1		1	UR STD
	94703-00330	PLUG, SPARK (NGK-R CR8E)				1	UR STD
	94701-00329	PLUG, SPARK (U24ESR-N)	1	1		1	UR STD
	94703-00329	PLUG, SPARK (U24ESR-N)				1	UR STD
	94701-00318	PLUG, SPARK (NGK R CR9E)	1	1		1	UR AP
	94703-00318	PLUG, SPARK (NGK R CR9E)				1	UR AP
	94701-00319	PLUG, SPARK (ND U27ESR-N)	1	1		1	UR AP
	94703-00319	PLUG, SPARK (ND U27ESR-N)				1	UR AP
13	5JG-11181-00	GASKET, CYLINDER HEAD 1	1	1	1	1	
14	90105-104A7	BOLT, WASHER BASED	2	2	2	2	
15	90105-106A3	BOLT, WASHER BASED	2	2	2	2	
16	90201-101A4	WASHER, PLATE	4	4	4	4	
17	5BE-11191-00	COVER, CYLINDER HEAD 1	1	1	1	1	
18	5BE-11167-00	PIPE, BREATHER 2	1	1	1	1	
19	90109-066F0	BOLT	2	2	2	2	
20	4KG-1111G-00	RUBBER, MOUNT 1	2	2	2	2	

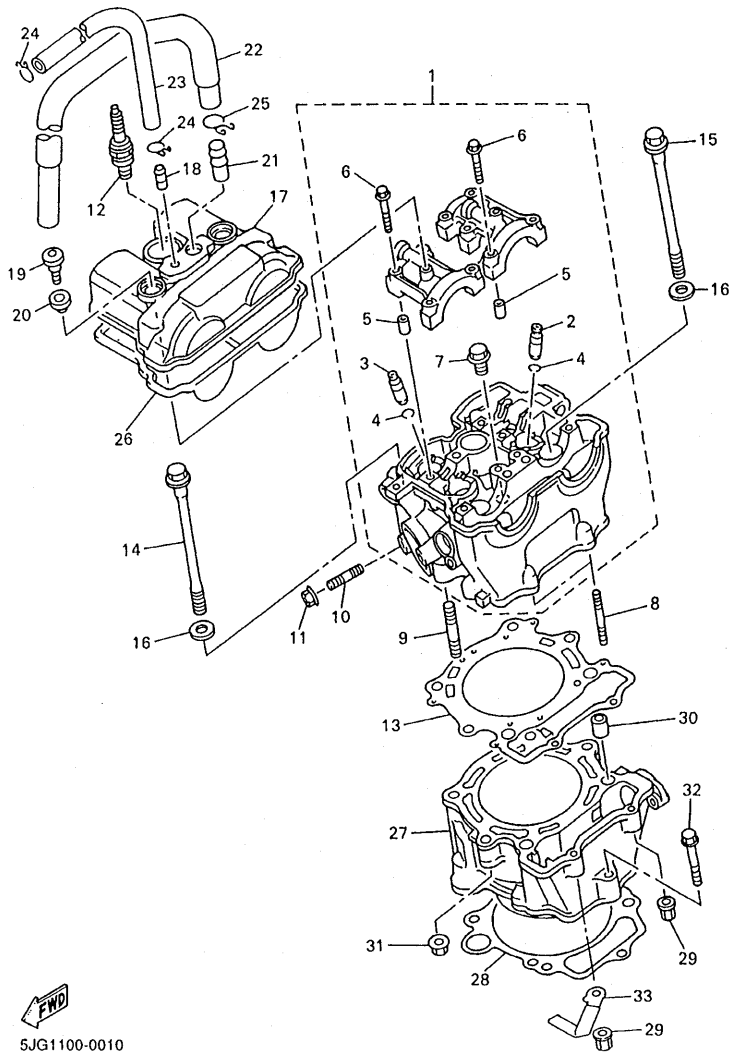

5JG1100-0010

FIG. 1 CYLINDER

REF. NO.	PART NO.	DESCRIPTION					REMARKS
			5JG1	5JG2	5JG3	5JG4	
21	371-11167-01	PIPE, BREATHER 2	1	1	1	1	
22	5BE-11166-00	PIPE, BREATHER 1	1	1	1	1	
23	90445-112K0	HOSE	1	1	1	1	
24	90467-11106	CLIP	2	2	2	2	
25	90467-14015	CLIP	1	1	1	1	
26	5BE-11193-10	GASKET, HEAD COVER 1	1	1	1	1	
27	5JG-11311-00	CYLINDER 1	1	1	1	1	
28	5BE-11351-00	GASKET, CYLINDER	1	1	1	1	
29	90179-06500	NUT	2	2	2	2	
30	93612-16254	PIN, DOWEL	2	2	2	2	
31	90179-08270	NUT	2	2	2	2	
32	95027-06040	BOLT, FLANGE	1	1	1	1	
33	5JG-11387-00	CLAMP, HOSE 1	1	1	1	1	

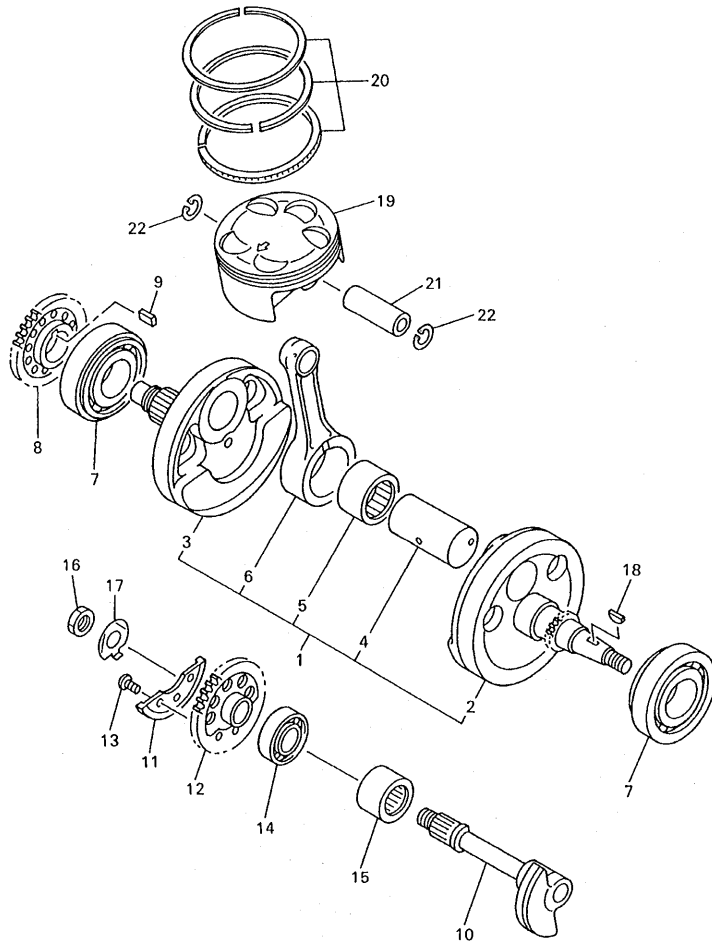

**FWD**  
5BE100-8020

**FIG. 2 CRANKSHAFT, PISTON**

REF. NO.	PART NO.	DESCRIPTION	5JG1	5JG2	5JG3	5JG4	REMARKS
1	5JG-11400-00	CRANKSHAFT ASSY	1	1	1	1	
2	5JG-11412-00	.CRANK 1	1	1	1	1	
3	5JG-11422-00	.CRANK 2	1	1	1	1	
4	5BE-11681-00	.PIN, CRANK 1	1	1	1	1	
5	93310-634B0	.BEARING	1	1	1	1	
6	5JG-11651-00	.ROD, CONNECTING	1	1	1	1	
7	93306-30633	BEARING	2	2	2	2	
8	5BE-11536-00	GEAR, DRIVE	1	1	1	1	
9	90282-05058	KEY, STRAIGHT	1	1	1	1	
10	5BE-11455-00	SHAFT 1	1	1	1	1	
11	5BE-11454-00	WEIGHT 1	1	1	1	1	
12	5BE-11531-00	GEAR, BALANCE WT	1	1	1	1	
13	90149-06250	SCREW	3	3	3	3	
14	93306-20335	BEARING	1	1	1	1	
15	93311-62574	BEARING	1	1	1	1	
16	90170-14171	NUT	1	1	1	1	
17	90215-14204	WASHER, LOCK	1	1	1	1	
18	90280-03017	KEY, WOODRUFF	1	1	1	1	
19	5JG-11631-00	PISTON (STD)	1	1	1	1	
20	5JG-11603-00	PISTON RING SET (STD)	1	1	1	1	
21	5JG-11633-00	PIN, PISTON	1	1	1	1	
22	93420-19084	CIRCLIP	2	2	2	2	



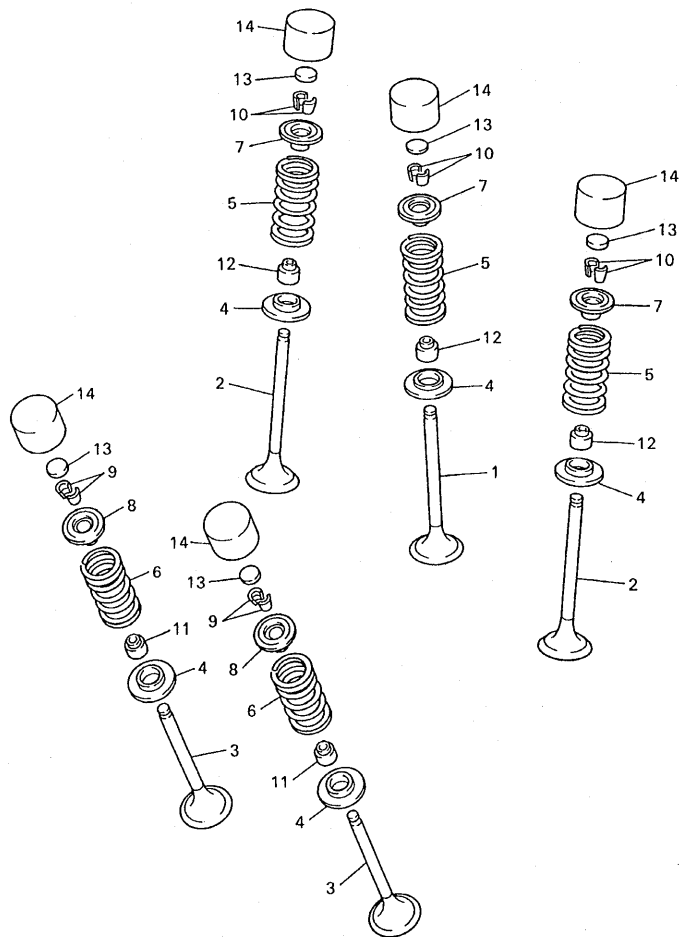

5BE100-8030

FIG. 3 VALVE

REF. NO.	PART NO.	DESCRIPTION	5UG1	5UG2	5UG3	5UG4	REMARKS
1	5BE-12111-10	VALVE, INTAKE	1	1	1	1	
2	5BE-12112-10	VALVE, INTAKE 2	2	2	2	2	
3	5BE-12121-10	VALVE, EXHAUST	2	2	2	2	
4	3GM-12126-00	SEAT, VALVE SPRING 2	5	5	5	5	
5	5BE-12113-00	SPRING, VALVE INNER	3	3	3	3	
6	5GR-12114-00	SPRING, VALVE OUTER	2	2	2	2	
7	5BE-12117-00	RETAINER, VALVE SPRING	3	3	3	3	
8	4GY-12117-00	RETAINER, VALVE SPRING	2	2	2	2	
9	1AA-12118-00	COTTER, VALVE	4	4	4	4	
10	1WG-12118-00	COTTER, VALVE	6	6	6	6	
11	33M-12119-00	SEAL, VALVE STEM	2	2	2	2	
12	4SV-12119-00	SEAL, VALVE STEM	3	3	3	3	
13	3LD-12168-00	PAD, ADJUSTING (1.20)	5	5	5	5	UR
	3LD-12168-20	PAD, ADJUSTING (1.25)	5	5	5	5	UR
	3LD-12168-40	PAD, ADJUSTING (1.30)	5	5	5	5	UR
	3LD-12168-60	PAD, ADJUSTING (1.35)	5	5	5	5	UR
	3LD-12168-80	PAD, ADJUSTING (1.40)	5	5	5	5	UR
	3LD-12168-A0	PAD, ADJUSTING (1.45)	5	5	5	5	UR
	3LD-12168-F0	PAD, ADJUSTING (1.50)	5	5	5	5	UR
	3LD-12168-H1	PAD, ADJUSTING (1.55)	5	5	5	5	UR
	3LD-12168-K1	PAD, ADJUSTING (1.60)	5	5	5	5	UR
	3LD-12168-M1	PAD, ADJUSTING (1.65)	5	5	5	5	UR
	3LD-12168-R1	PAD, ADJUSTING (1.70)	5	5	5	5	UR
	3LD-12168-U1	PAD, ADJUSTING (1.75)	5	5	5	5	UR
	3LD-12168-W1	PAD, ADJUSTING (1.80)	5	5	5	5	UR
	3LD-12168-Y1	PAD, ADJUSTING (1.85)	5	5	5	5	UR
	3LD-12169-11	PAD, ADJUSTING (1.90)	5	5	5	5	UR

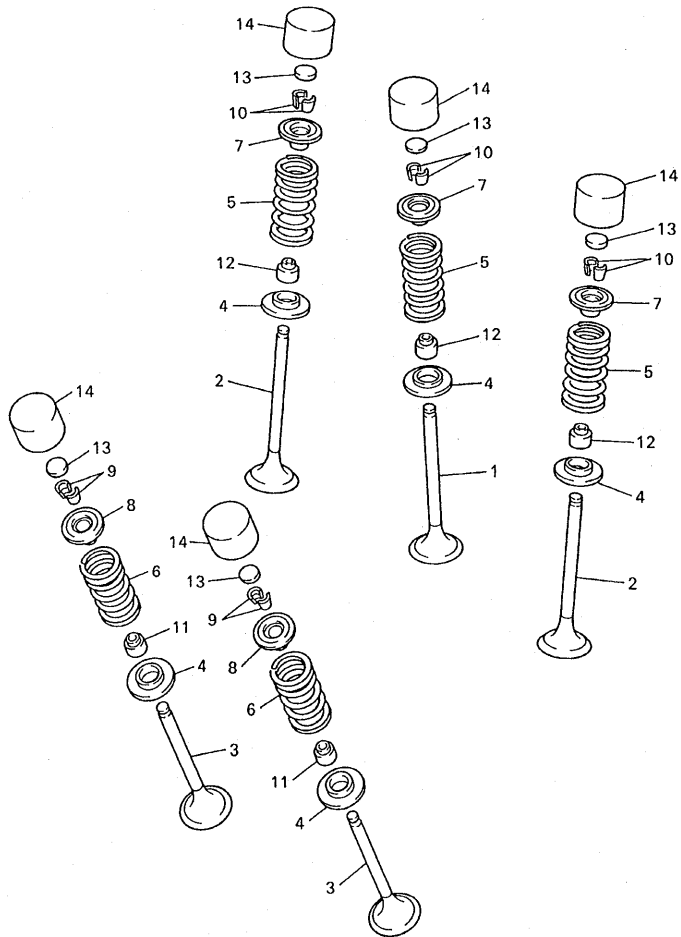

5BE100-8030

FIG. 3 VALVE

REF. NO.	PART NO.	DESCRIPTION	B/G1	B/G2	B/G3	B/G4	REMARKS
13	3LD-12169-31	PAD, ADJUSTING (1.95)	5	5	5	5	UR
	3LD-12169-50	PAD, ADJUSTING (2.00)	5	5	5	5	UR
	3LD-12169-70	PAD, ADJUSTING (2.05)	5	5	5	5	UR
	3LD-12169-90	PAD, ADJUSTING (2.10)	5	5	5	5	UR
	3LD-12169-E0	PAD, ADJUSTING (2.15)	5	5	5	5	UR
	3LD-12169-G0	PAD, ADJUSTING (2.20)	5	5	5	5	UR
	3LD-12169-J0	PAD, ADJUSTING (2.25)	5	5	5	5	UR
	3LD-12169-L0	PAD, ADJUSTING (2.30)	5	5	5	5	UR
	3LD-12169-N0	PAD, ADJUSTING (2.35)	5	5	5	5	UR
	3LD-12169-T0	PAD, ADJUSTING (2.40)	5	5	5	5	UR
14	3FV-12153-00	LIFTER, VALVE	5	5	5	5	UR BLACK
	3FV-12153-10	LIFTER, VALVE	5	5	5	5	UR YELLOW
	3FV-12153-20	LIFTER, VALVE	5	5	5	5	UR BLUE

FIG. 4 CAMSHAFT. CHAIN

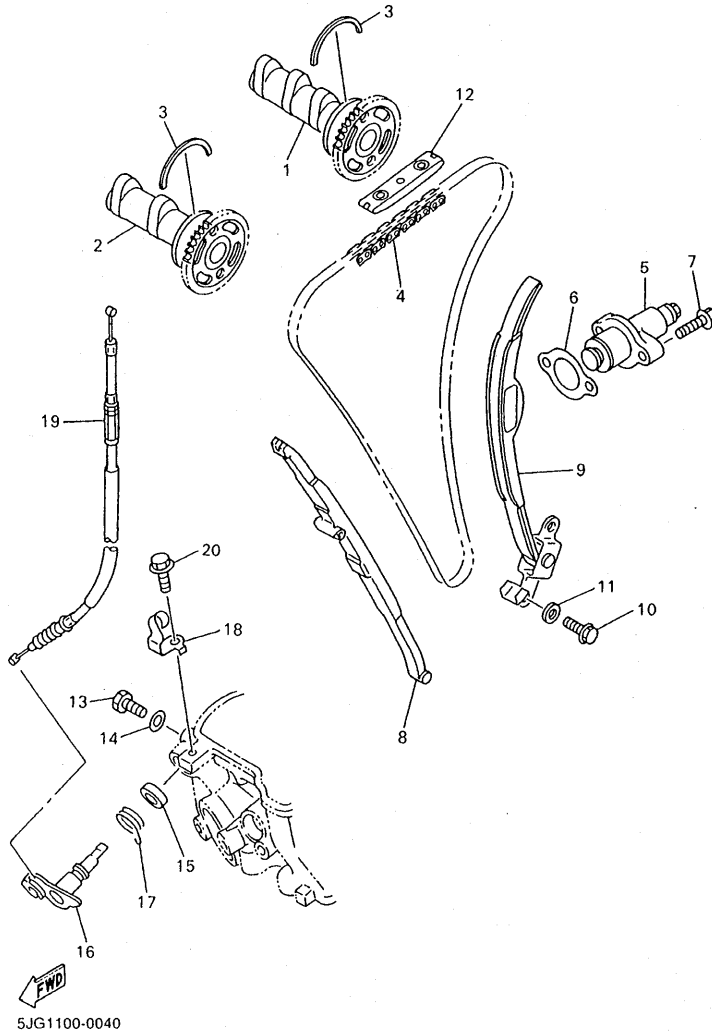

REF. NO.	PART NO.	DESCRIPTION					REMARKS
			SJG1	SJG2	SJG3	SJG4	
1	5BE-12170-00	CAMSHAFT ASSY 1	1	1	1	1	
2	5BE-12180-00	CAMSHAFT ASSY 2	1	1	1	1	
3	93440-41178	CIRCLIP	2	2	2	2	
4	94591-50120	CHAIN	1	1	1	1	
5	5BE-12210-00	TENSIONER ASSY, CAM CHAIN	1	1	1	1	
6	4FM-12213-00	GASKET, TENSIONER CASE	1	1	1	1	
7	95027-06025	BOLT, FLANGE	2	2	2	2	
8	5BE-12251-10	DAMPER, CHAIN 1	1	1	1	1	
9	5BE-12252-00	DAMPER, CHAIN 2	1	1	1	1	
10	97027-06016	BOLT	2	2	2	2	
11	92907-06600	WASHER, PLATE	2	2	2	2	
12	5BE-12241-00	GUIDE, STOPPER 2	1	1	1	1	
13	90109-06418	BOLT	1	1	1	1	
14	90430-06014	GASKET	1	1	1	1	
15	93102-12224	OIL SEAL	1	1	1	1	
16	5BE-12280-10	DECOMPRESSION ASSY	1	1	1	1	
17	90508-162B2	SPRING, TORSION	1	1	1	1	
18	5BE-12283-00	BRACKET, DECOMPRESSION	1	1	1	1	
19	5BE-12292-00	CABLE, DECOMPRESSION	1	1	1	1	
20	95827-06014	BOLT, FLANGE	1	1	1	1	

FIG. 5 WATER PUMP

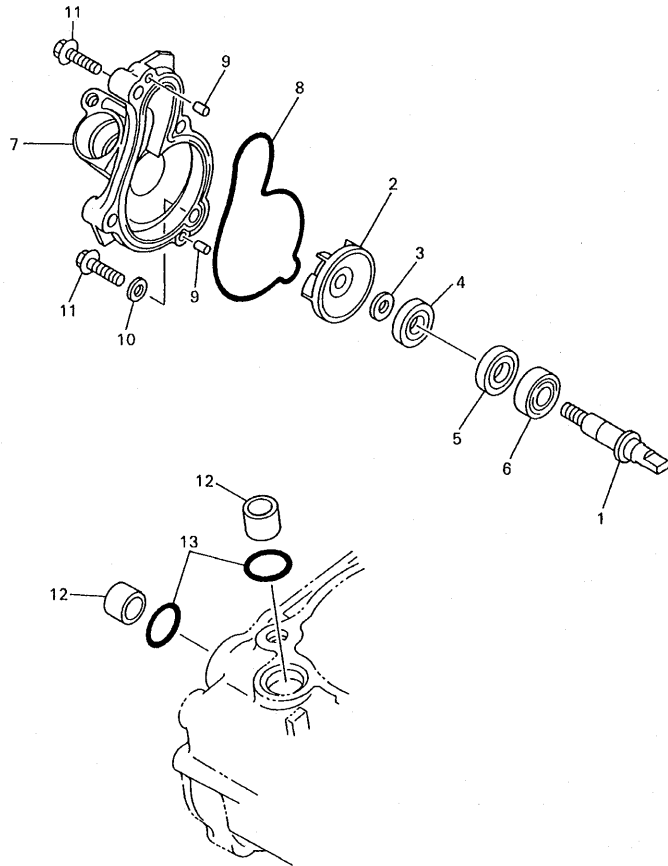

REF. NO.	PART NO.	DESCRIPTION					REMARKS
			5UG1	5UG2	5UG3	5UG4	
1	5GR-12458-00	SHAFT, IMPELLER	1	1	1	1	
2	5DJ-12451-00	IMPELLER, WATER PUMP	1	1	1	1	
3	90201-08512	WASHER, PLATE	1	1	1	1	
4	93109-11073	OIL SEAL	1	1	1	1	
5	93102-12106	OIL SEAL (SD 12-22-5 HS)	1	1	1	1	
6	93306-00105	BEARING (B6001)	1	1	1	1	
7	5BE-12422-10	COVER, HOUSING	1	1	1	1	
8	5BE-12439-00	O-RING	1	1	1	1	
9	93604-10011	PIN, DOWEL	2	2	2	2	
10	90430-06014	GASKET	1	1	1	1	
11	95027-06025	BOLT, FLANGE	4	4	4	4	
12	5BE-12564-00	PIPE, WATER	2	2	2	2	
13	93210-19758	O-RING	2	2	2	2	



5BE100-8050

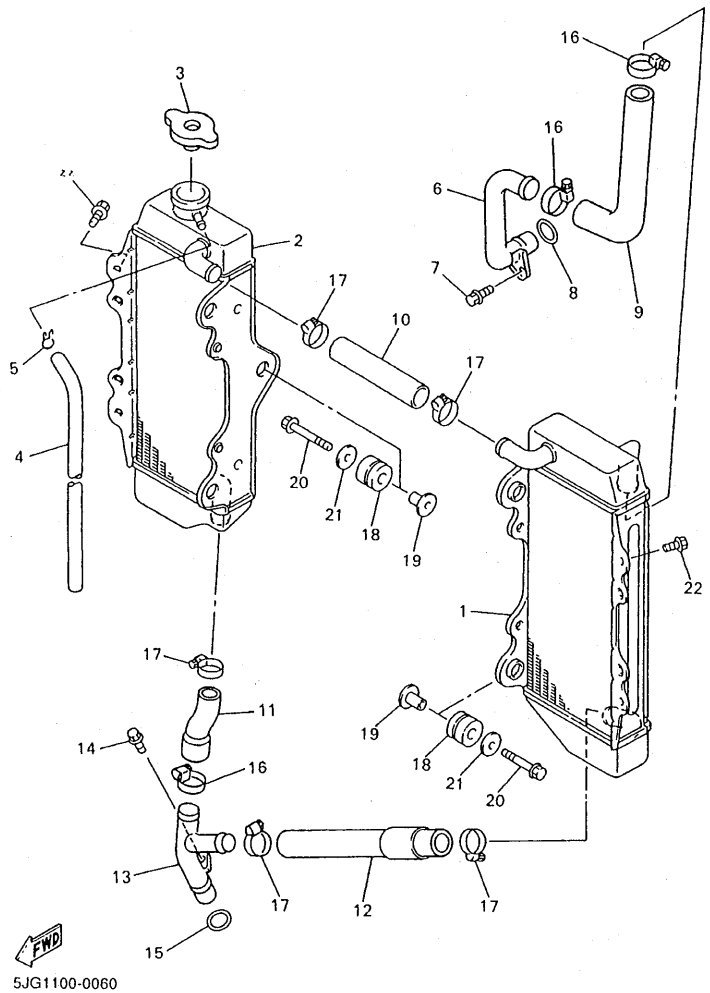
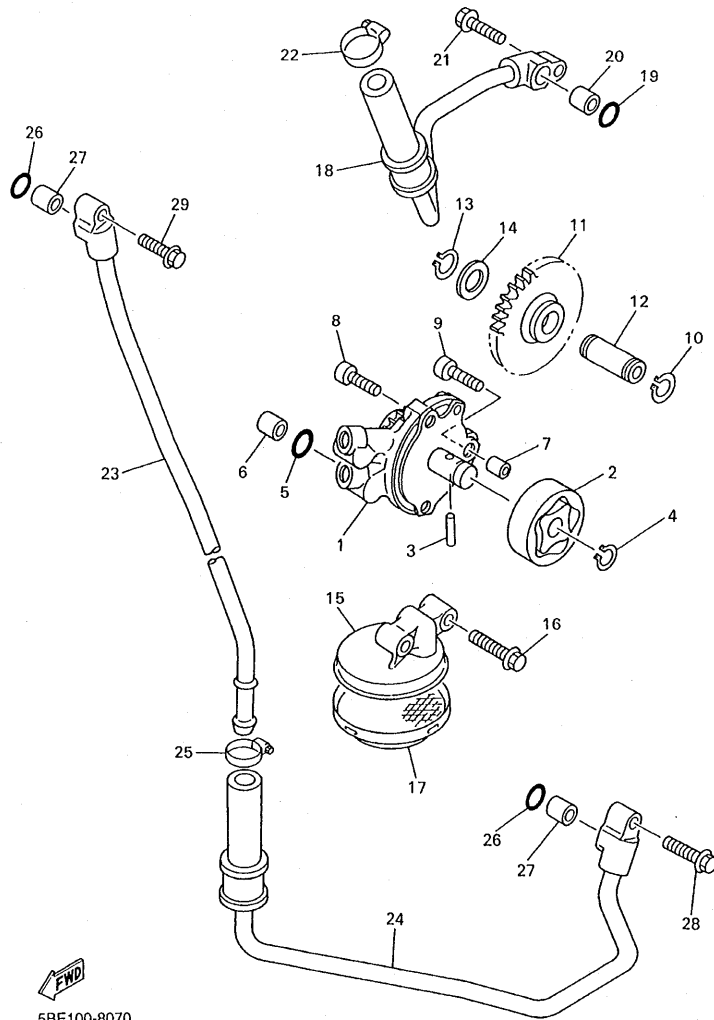

FIG. 6 RADIATOR. HOSE

REF. NO.	PART NO.	DESCRIPTION					REMARKS
			5JG1	5JG2	5JG3	5JG4	
1	5JG-1240A-00	RADIATOR ASSY	1	1	1	1	
2	5JG-12461-00	RADIATOR ASSY	1	1	1	1	
3	5HD-12462-00	CAP, RADIATOR	1	1	1	1	
4	91A20-05065	TUBE, FLEXIBLE VINYL	1	1	1	1	
5	90467-09006	CLIP	1	1	1	1	
6	5BE-12481-10	PIPE 1	1	1	1	1	
7	95027-06012	BOLT, FLANGE	1	1	1	1	
8	93210-16500	O-RING	1	1	1	1	
9	5BE-12576-00	HOSE 1	1	1	1	1	
10	5BE-12577-00	HOSE 2	1	1	1	1	
11	5BE-12578-00	HOSE 3	1	1	1	1	
12	5BE-12579-01	HOSE 4	1	1	1	1	
13	5BE-12482-00	PIPE 2	1	1	1	1	
14	95027-06012	BOLT, FLANGE	1	1	1	1	
15	93210-16500	O-RING	1	1	1	1	
16	90450-28014	HOSE CLAMP ASSY	3	3	3	3	
17	90450-25037	HOSE CLAMP ASSY	5	5	5	5	
18	90480-15528	GROMMET	6	6	6	6	
19	90387-0614M	COLLAR	6	6	6	6	
20	95027-06025	BOLT, FLANGE	6	6	6	6	
21	90201-06071	WASHER, PLATE	6	6	6	6	
22	95827-06010	BOLT, FLANGE	2	2	2	2	

FIG. 7 OIL PUMP



  
5BE100-8070

REF. NO.	PART NO.	DESCRIPTION					REMARKS
			5JG1	5JG2	5JG3	5JG4	
1	5BE-13300-00	OIL PUMP ASSY	1	1	1	1	
2	1HX-13310-00	ROTOR ASSY 1	1	1	1	1	
3	93603-17070	PIN, DOWEL	1	1	1	1	
4	93440-10085	CIRCLIP	1	1	1	1	
5	93210-10197	O-RING	1	1	1	1	
6	99530-10114	PIN, DOWEL	1	1	1	1	
7	99530-08012	PIN, DOWEL	1	1	1	1	
8	91317-06025	BOLT	2	2	2	2	
9	91314-06030	BOLT	1	1	1	1	
10	99001-08600	CIRCLIP	1	1	1	1	
11	5BE-13341-00	GEAR, OIL PUMP IDLE	1	1	1	1	
12	5BE-13342-00	SHAFT, IDLE GEAR	1	1	1	1	
13	99009-12400	CIRCLIP	1	1	1	1	
14	90201-12166	WASHER, PLATE	1	1	1	1	
15	5BE-13412-00	HOUSING, STRAINER	1	1	1	1	
16	95027-06025	BOLT, FLANGE	2	2	2	2	
17	5BE-13411-00	STRAINER, OIL	1	1	1	1	
18	5BE-13464-00	HOSE, OIL 1	1	1	1	1	
19	93210-10197	O-RING	1	1	1	1	
20	99530-10114	PIN, DOWEL	1	1	1	1	
21	95027-06025	BOLT, FLANGE	1	1	1	1	
22	90450-22017	HOSE CLAMP ASSY	1	1	1	1	
23	5BE-13416-00	PIPE, OIL 1	1	1	1	1	
24	5BE-13465-00	HOSE, OIL 2	1	1	1	1	
25	90450-22017	HOSE CLAMP ASSY	1	1	1	1	
26	93210-10197	O-RING	2	2	2	2	
27	99530-10114	PIN, DOWEL	2	2	2	2	

FIG. 7 OIL PUMP

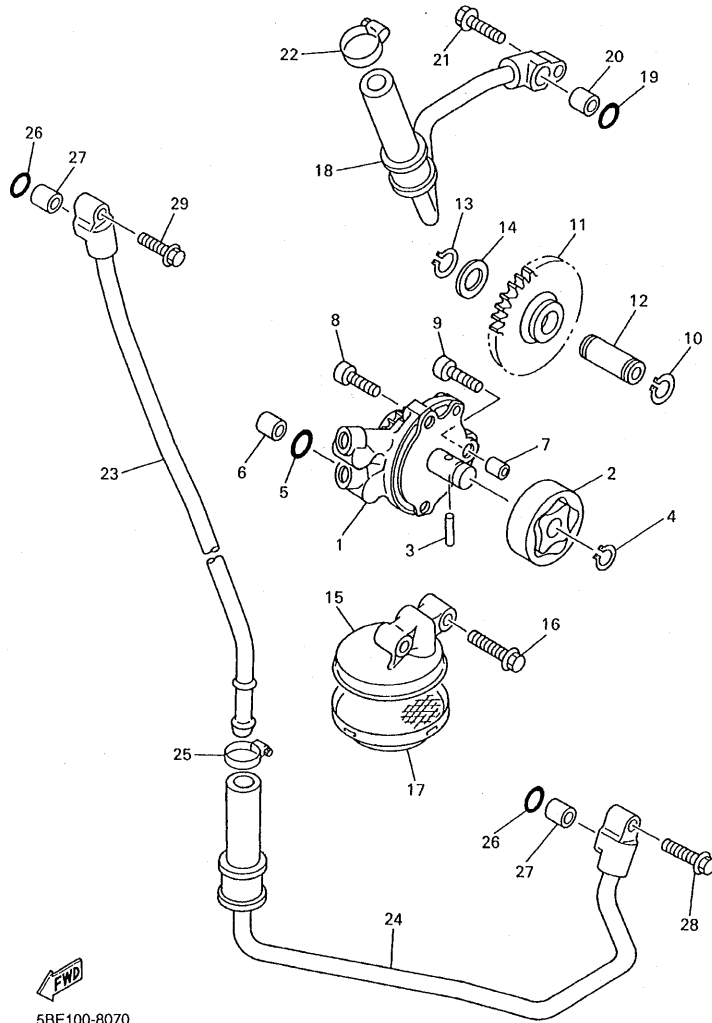

5BE100-8070

REF. NO.	PART NO.	DESCRIPTION					REMARKS
			SJG1	SJG2	SJG3	SJG4	
28	95027-06025	BOLT, FLANGE	1	1	1	1	
29	95024-06020	BOLT, FLANGE	1	1	1	1	

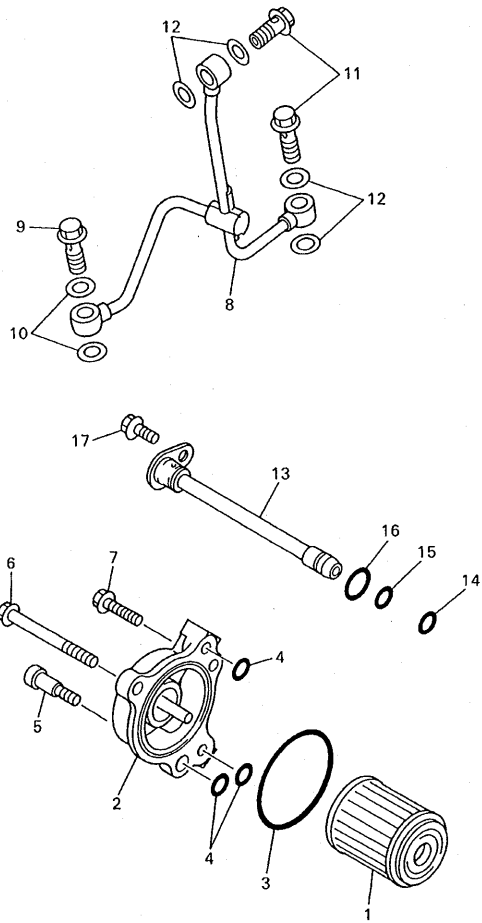

FIG. 8 OIL CLEANER

REF. NO.	PART NO.	DESCRIPTION					REMARKS
			SUG1	SUG2	SUG3	SUG4	
1	1UY-13440-02	ELEMENT ASSY, OIL CLEANER	1	1	1	1	
2	5BE-13447-00	COVER, OIL ELEMENT	1	1	1	1	
3	93210-50553	O-RING	1	1	1	1	
4	93210-07135	O-RING	3	3	3	3	
5	90109-065G2	BOLT	1	1	1	1	
6	95027-06065	BOLT, FLANGE	1	1	1	1	
7	95027-06020	BOLT, FLANGE	1	1	1	1	
8	5BE-13161-01	PIPE, DELIVERY 1	1	1	1	1	
9	90401-10159	BOLT, UNION	1	1	1	1	
10	90430-10188	GASKET	2	2	2	2	
11	90401-08038	BOLT, UNION	2	2	2	2	
12	90430-08119	GASKET	4	4	4	4	
13	5BE-13171-00	PIPE, DELIVERY 2	1	1	1	1	
14	93210-07003	O-RING	1	1	1	1	
15	93210-09008	O-RING	1	1	1	1	
16	93210-12759	O-RING	1	1	1	1	
17	95027-06012	BOLT, FLANGE	1	1	1	1	



5BE100-8080



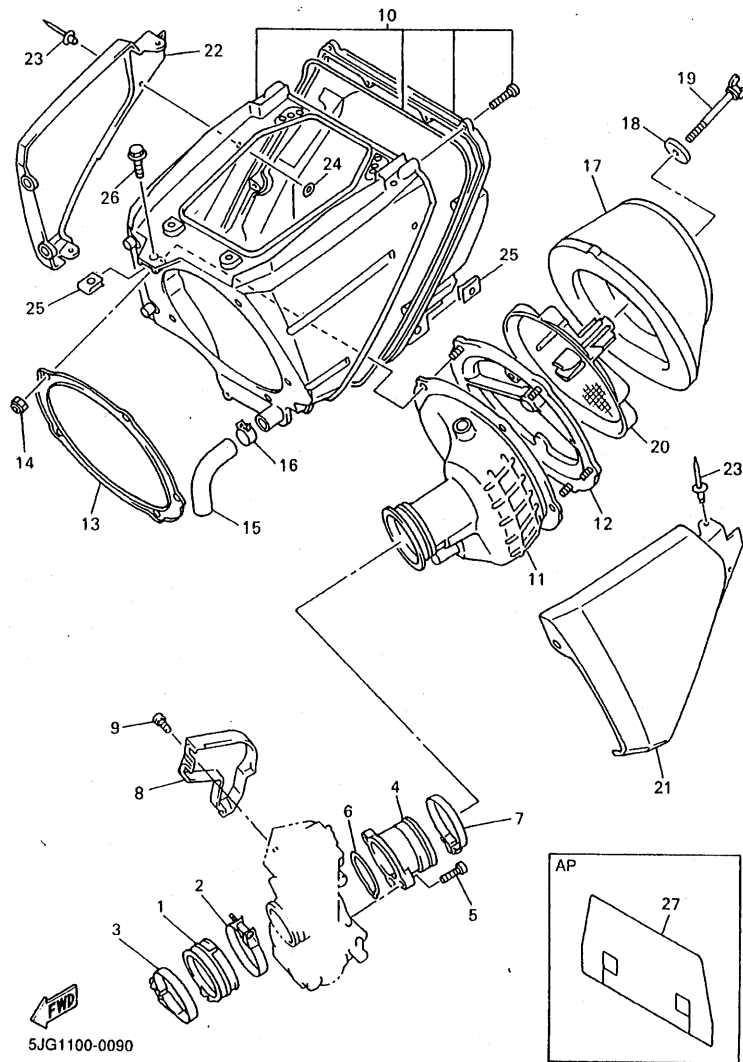

5JG1100-0090

FIG. 9 INTAKE

REF. NO.	PART NO.	DESCRIPTION	5JG1	5JG2	5JG3	5JG4	REMARKS
1	5JG-13597-00	JOINT, CARBURETOR 3	1	1	1	1	
2	90450-57092	HOSE CLAMP ASSY	1	1	1	1	
3	90450-59091	HOSE CLAMP ASSY	1	1	1	1	
4	5JG-1440F-00	JOINT, AIR FILTER 1	1	1	1	1	
5	91317-05014	BOLT	2	2	2	2	
6	4FN-14561-00	O-RING	1	1	1	1	
* 7	90450-61001	HOSE CLAMP ASSY	1	1	1	1	
8	5JG-14293-00	COVER 1	1	1	1	1	
9	5JG-14428-00	BOLT	1	1	1	1	
10	5JG-14401-00	AIR CLEANER CASE ASSY	1	1	1	1	
11	5JG-14453-00	JOINT, AIR CLEANER 1	1	1	1	1	
12	3JD-14459-01	HOLDER, GUIDE	1	1	1	1	
13	3JD-14477-00	PLATE	1	1	1	1	
14	95607-05100	NUT, U	5	5	5	5	
15	5BE-1443E-00	PIPE, DRAIN	1	1	1	1	
16	90467-17089	CLIP	1	1	1	1	
17	4XM-14451-00	ELEMENT, AIR CLEANER	1	1	1	1	
18	90209-06096	WASHER	1	1	1	1	
19	90122-06035	BOLT, WING	1	1	1	1	
20	5BE-14458-00	GUIDE	1	1	1	1	
21	5BE-1441A-00	COVER, CLEANER CASE 1	1	1	1	1	
22	5BE-1441E-00	COVER, CLEANER CASE 2	1	1	1	1	
23	90267-32070	RIVET, BLIND	5	5	5	5	
24	90201-03313	WASHER, PLATE	5	5	5	5	
25	90183-06023	NUT, SPRING	2	2	2	2	
26	95027-06012	BOLT, FLANGE	1	1	1	1	
27	5JG-14417-00	COVER 1	1	1	1	1	AP

FIG. 10 CARBURETOR

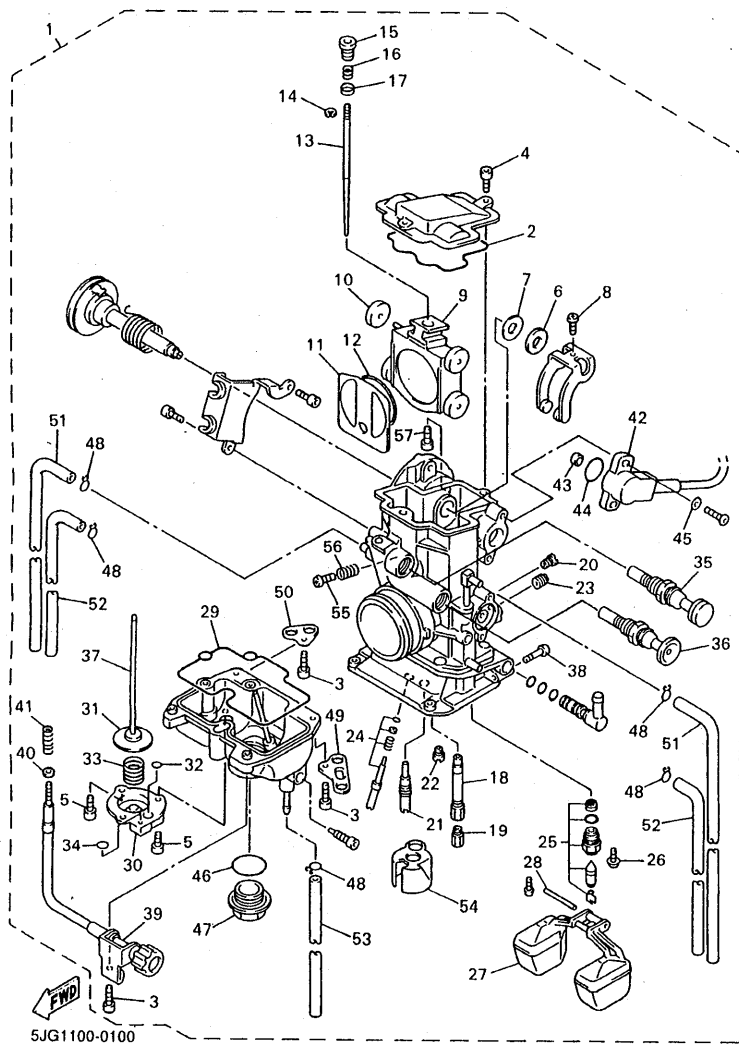

5JG1100-0100

REF. NO.	PART NO.	DESCRIPTION					REMARKS
			5JG1	5JG2	5JG3	5JG4	
1	5JG-14101-00	CARBURETOR ASSY 1	1				
	5JG-14101-10	CARBURETOR ASSY 1		1	1	1	
2	5JG-14959-00	.GASKET	1	1	1	1	
3	91316-04012	.BOLT	4	4	4	4	
4	91316-04012	.BOLT	2	2	2	2	
5	91316-04008	.BOLT	3	3	3	3	
6	90202-08045	.WASHER, PLATE	1	1	1	1	
7	5JG-14951-00	.WASHER	1	1	1	1	
8	5JG-14522-00	.SCREW, ADJUST	1	1	1	1	
9	5JG-14388-00	.VALVE, VACUUM CONTROL	1	1	1	1	
10	3TJ-14267-40	.ROLLER	1	1	1	1	
11	5JG-14546-00	.VALVE, NEEDLE	1	1	1	1	
12	4FN-14997-00	.SEAL	1	1	1	1	
*13	5JG-14916-ER	.NEEDLE (#EKR)	1				STD
	5JG-14916-E1	.NEEDLE (#EKQ)		1	1	1	STD
	5JG-14916-DN	.NEEDLE (#DKN)	1	1	1	1	AP
	5JG-14916-DP	.NEEDLE (#DKP)	1	1	1	1	AP
	5JG-14916-D1	.NEEDLE (#DKQ)	1	1	1	1	AP
	5JG-14916-DR	.NEEDLE (#DKR)	1	1	1	1	AP
	5JG-14916-DS	.NEEDLE (#DKS)	1	1	1	1	AP
	5JG-14916-DT	.NEEDLE (#DKT)	1	1	1	1	AP
	5JG-14916-DU	.NEEDLE (#DKU)	1	1	1	1	AP
	5JG-14916-EN	.NEEDLE (#EKN)	1	1	1	1	AP
	5JG-14916-EP	.NEEDLE (#EKP)	1	1	1	1	AP
	5JG-14916-E1	.NEEDLE (#EKQ)	1				AP
	5JG-14916-ER	.NEEDLE (#EKR)		1	1	1	AP
	5JG-14916-ES	.NEEDLE (#EKS)	1	1	1	1	AP

FIG. 10 CARBURETOR

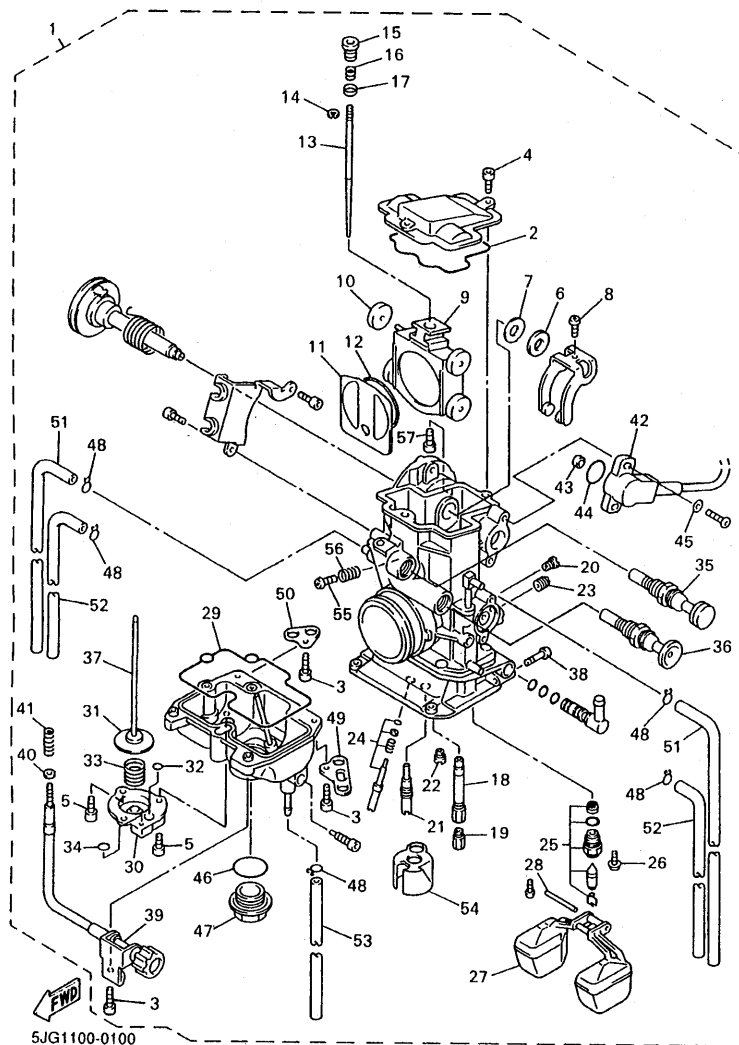

REF. NO.	PART NO.	DESCRIPTION					REMARKS
			5JG1	5JG2	5JG3	5JG4	
*13	5JG-14916-ET	.NEEDLE (#EKT)	1	1	1	1	AP
	5JG-14916-EU	.NEEDLE (#EKU)	1	1	1	1	AP
	5JG-14916-FN	.NEEDLE (#FKN)	1	1	1	1	AP
	5JG-14916-FP	.NEEDLE (#FKP)	1	1	1	1	AP
	5JG-14916-F1	.NEEDLE (#FKQ)	1	1	1	1	AP
	5JG-14916-FR	.NEEDLE (#FKR)	1	1	1	1	AP
	5JG-14916-FS	.NEEDLE (#FKS)	1	1	1	1	AP
	5JG-14916-FT	.NEEDLE (#FKT)	1	1	1	1	AP
	5JG-14916-FU	.NEEDLE (#FKU)	1	1	1	1	AP
14	3TJ-14159-40	.CLIP	1	1	1	1	
15	5JG-14521-00	.SCREW, ADJUST	1	1	1	1	
16	5JG-14275-00	.SPRING	1	1	1	1	
17	5JG-14264-00	.COLLAR	1	1	1	1	
18	5JG-14947-00	.JET, NEEDLE	1	1	1	1	
19	4MX-14943-90	.JET, MAIN (#162)	1	1	1	1	STD
	4MX-14943-88	.JET, MAIN (#152)	1	1	1	1	AP
	4MX-14943-38	.JET, MAIN (#155)	1	1	1	1	AP
	4MX-14943-89	.JET, MAIN (#158)	1	1	1	1	AP
	4MX-14943-39	.JET, MAIN (#160)	1	1	1	1	AP
	4MX-14943-40	.JET, MAIN (#165)	1	1	1	1	AP
	4MX-14943-91	.JET, MAIN (#168)	1	1	1	1	AP
	4MX-14943-41	.JET, MAIN (#170)	1	1	1	1	AP
	4MX-14943-92	.JET, MAIN (#172)	1	1	1	1	AP
	4MX-14943-42	.JET, MAIN (#175)	1	1	1	1	AP
	4MX-14943-93	.JET, MAIN (#178)	1	1	1	1	AP
20	3TJ-14943-47	.JET (#200)	1	1	1	1	
21	4MX-14948-04	.JET, SLOW (#42)	1	1	1	1	STD

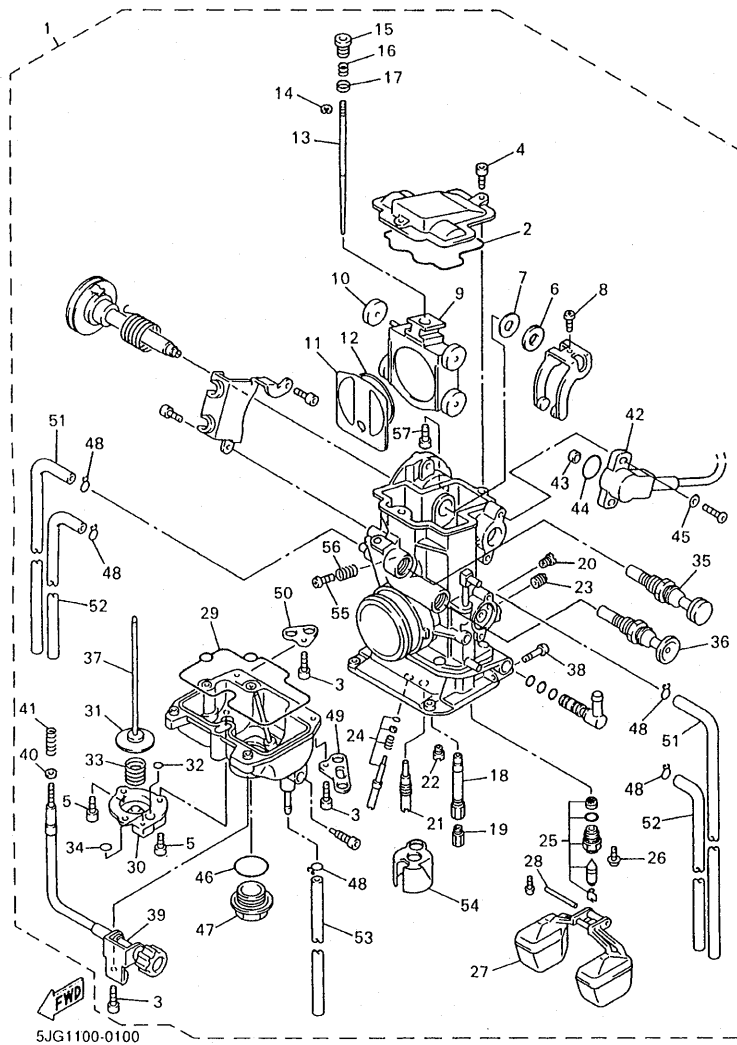

5JG1100-0100

FIG. 10 CARBURETOR

REF. NO.	PART NO.	DESCRIPTION	SUG1	SUG2	SUG3	SUG4	REMARKS
21	4MX-14948-01	.JET, SLOW (#35)	1	1	1	1	AP
	4MX-14948-02	.JET, SLOW (#38)	1	1	1	1	AP
	4MX-14948-03	.JET, SLOW (#40)	1	1	1	1	AP
	4MX-14948-05	.JET, SLOW (#45)	1	1	1	1	AP
	4MX-14948-06	.JET, SLOW (#48)	1	1	1	1	AP
	4MX-14948-07	.JET, SLOW (#50)	1	1	1	1	AP
22	3TJ-1494F-16	.JET (#72)	1	1	1	1	STD
	3TJ-1494F-12	.JET (#62)	1	1	1	1	AP
	3TJ-1494F-13	.JET (#65)	1	1	1	1	AP
	3TJ-1494F-14	.JET (#68)	1	1	1	1	AP
	3TJ-1494F-15	.JET (#70)	1	1	1	1	AP
	3TJ-1494F-17	.JET (#75)	1	1	1	1	AP
	3TJ-1494F-18	.JET (#78)	1	1	1	1	AP
	3TJ-1494F-19	.JET (#80)	1	1	1	1	AP
	3TJ-1494F-20	.JET (#82)	1	1	1	1	AP
23	7A9-14943-27	.JET (#100)	1	1	1	1	
24	3TJ-14105-40	.PILOT SCREW SET	1	1	1	1	
25	5BE-14107-00	.NEEDLE VALVE SET	1	1	1	1	
26	5BE-14216-00	.SCREW	1	1	1	1	
27	4SR-14985-00	.FLOAT	1	1	1	1	
28	676-14548-00	.PIN, FLOAT ARM	1	1	1	1	
29	5JG-14984-00	.GASKET, FLOAT CHAMBER	1	1	1	1	
30	3TJ-14293-40	.COVER 1	1	1	1	1	
31	5BE-14940-18	.DIAPHRAGM ASSY	1	1	1	1	STD
	5BE-14940-15	.DIAPHRAGM ASSY	1	1	1	1	AP
	5BE-14940-17	.DIAPHRAGM ASSY	1	1	1	1	AP
	5BE-14940-19	.DIAPHRAGM ASSY	1	1	1	1	AP

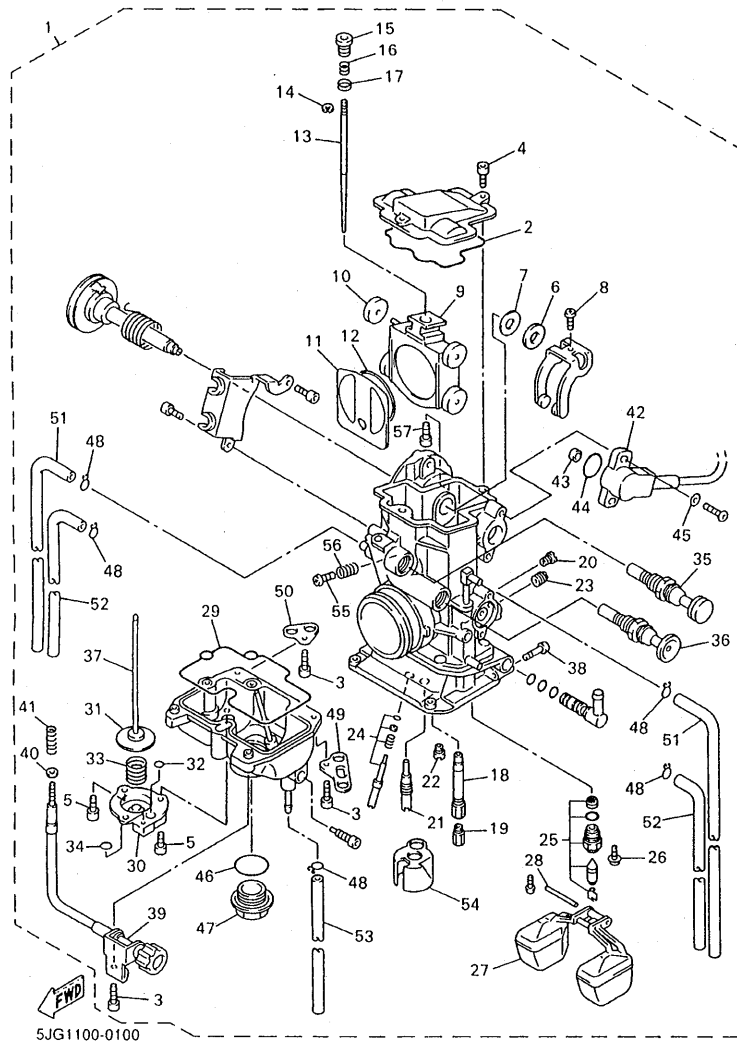
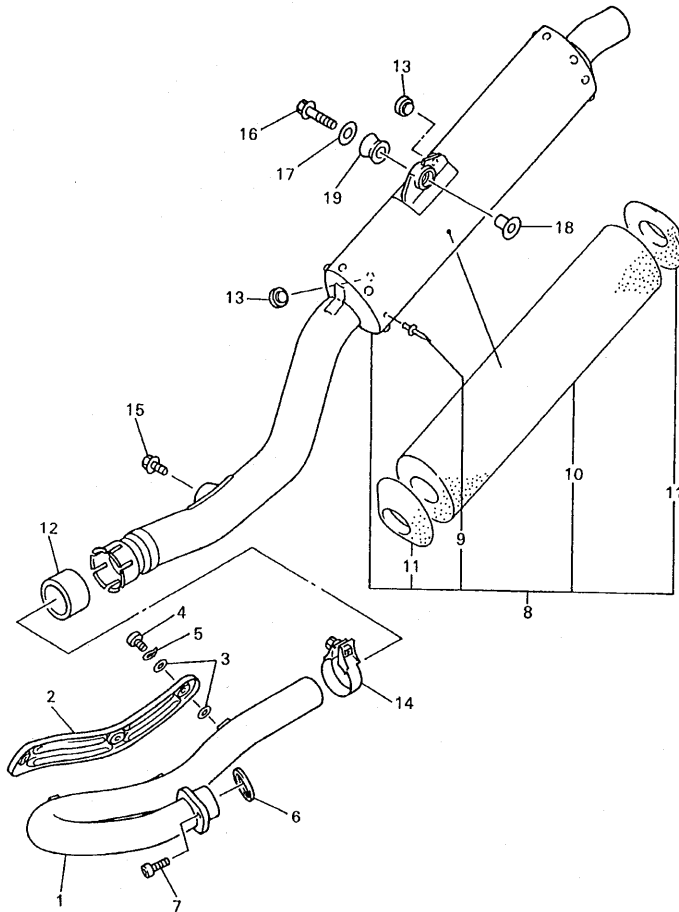

FIG. 10 CARBURETOR

REF. NO.	PART NO.	DESCRIPTION					REMARKS
			5JG1	5JG2	5JG3	5JG5	
32	3TJ-14536-40	.GASKET	1	1	1	1	
33	3TJ-14933-40	.SPRING, DIAPHRAGM	1	1	1	1	
34	6H4-14561-00	.O-RING	1	1	1	1	
35	5JG-14171-00	.PLUNGER, STARTER	1	1	1	1	
36	5JG-14371-00	.PLUNGER, STARTER	1	1	1	1	
37	5JG-14379-00	.ROD, STARTER	1	1	1	1	
38	3TJ-14325-40	.SCREW, PAN HEAD	1	1	1	1	
39	5JG-14922-00	.SCREW, THROTTLE	1	1	1	1	
40	90201-08410	.WASHER, PLATE	1	1	1	1	
41	4FN-14934-00	.SPRING, THROTTLE STOP	1	1	1	1	
42	5JG-85885-00	.THROTTLE SENSOR ASSY	1	1	1	1	
43	5BE-14449-00	.COLLAR	1	1	1	1	
44	5BE-14562-00	.O-RING	1	1	1	1	
45	4YR-14557-00	.WASHER	2	2	2	2	
46	4MX-14561-00	.O-RING	1	1	1	1	
47	4MX-14115-00	.PLUG, SCREW	1	1	1	1	
48	3TJ-14137-40	.CLIP	5	5	5	5	
49	5JG-14146-00	.PLATE	1	1	1	1	
50	5BE-14146-00	.PLATE	1	1	1	1	
51	5JG-14197-00	.PIPE	2	2	2	2	
52	5JG-14197-10	.PIPE	2	2	2	2	
53	5JG-14987-00	.HOSE	1	1	1	1	
54	5JG-14346-00	.PLATE	1	1	1	1	
55	5JG-14565-00	.SCREW	1	1	1	1	
56	5JG-14531-00	.SPRING, ADJUST SCREW	1	1	1	1	
57	5JG-14591-00	.SCREW	1	1	1	1	

FIG. 11 EXHAUST



  
5BE100-8111

REF. NO.	PART NO.	DESCRIPTION					REMARKS
			5JG1	5JG2	5JG3	5JG4	
1	5BE-14611-00	PIPE, EXHAUST 1	1	1	1	1	
2	5BE-14628-00	PROTECTOR, EXHAUST PIPE	1	1	1	1	
3	4BD-14766-00	WASHER, PROTECTOR	6	6	6	6	
4	98980-06008	SCREW, BIND	3	3	3	3	
5	90206-06090	WASHER, WAVE	3	3	3	3	
6	3VD-14613-00	GASKET, EXHAUST PIPE	1	1	1	1	
7	91317-08020	BOLT	1	1	1	1	
8	5JG-14753-00	SILENCER, EXHAUST	1				
	5JG-14753-10	SILENCER, EXHAUST		1	1	1	
9	90267-48121	.RIVET, BLIND	8	8	8	8	
10	5JG-1469A-00	.FIBER	1				
	5BE-1469A-10	.FIBER		1	1	1	
11	5BE-1469E-00	.FIBER	2	2	2	2	
12	3GW-14714-00	GASKET, MUFFLER	1	1	1	1	
13	22W-24181-00	DAMPER, LOCATING 1	2	2	2	2	
14	5BE-14788-00	BAND, SILENCER	1	1	1	1	
15	95817-08012	BOLT, FLANGE	1	1	1	1	
16	95817-08030	BOLT, FLANGE	1	1	1	1	
17	90201-081R9	WASHER, PLATE	1	1	1	1	
18	90387-0814J	COLLAR	1	1	1	1	
19	5BE-14747-00	DAMPER, MUFFLER	1	1	1	1	

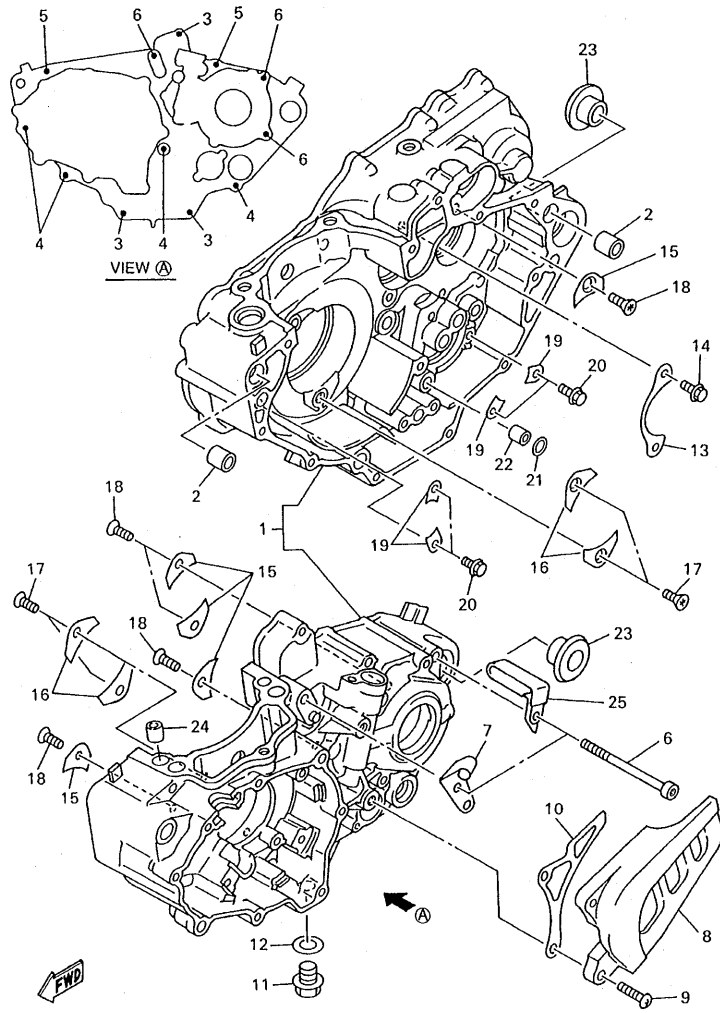

5BE100-8120

FIG. 12 CRANKCASE

REF. NO.	PART NO.	DESCRIPTION					REMARKS
			5/G1	5/G2	5/G3	5/G4	
1	5BE-15150-02	CRANKCASE ASSY	1	1	1	1	
2	99530-14016	PIN, DOWEL	2	2	2	2	
3	91317-06040	BOLT	3	3	3	3	
4	91317-06050	BOLT	4	4	4	4	
5	91317-06060	BOLT	2	2	2	2	
6	91317-06075	BOLT	3	3	3	3	
7	5BE-15441-00	HOLDER, CLUTCH CABLE	1	1	1	1	
8	5BE-15421-00	COVER, CRANKCASE 2	1	1	1	1	
9	98507-06025	SCREW, PAN HEAD	2	2	2	2	
10	5BE-17466-10	GUIDE, CHAIN	1	1	1	1	
11	90340-12059	PLUG, STRAIGHT SCREW	1	1	1	1	
12	90430-12213	GASKET	1	1	1	1	
13	4L0-17471-00	PLATE, COVER	1	1	1	1	
14	90105-06553	BOLT, WASHER BASED	2	2	2	2	
15	4JT-15381-01	PLATE, BEARING COVER	5	5	5	5	
16	5BE-15383-00	PLATE, BEARING COVER	4	4	4	4	
17	90151-06002	SCREW, COUNTERSUNK	4	4	4	4	
18	90149-06326	SCREW	5	5	5	5	
19	5DH-18562-00	PLATE, STOPPER 2	4	4	4	4	
20	90105-06553	BOLT, WASHER BASED	4	4	4	4	
21	93210-10197	O-RING	1	1	1	1	
22	99530-10114	PIN, DOWEL	1	1	1	1	
23	90387-1712Y	COLLAR	2	2	2	2	
24	99530-10116	PIN, DOWEL	2	2	2	2	
25	90461-10136	CLAMP	1	1	1	1	

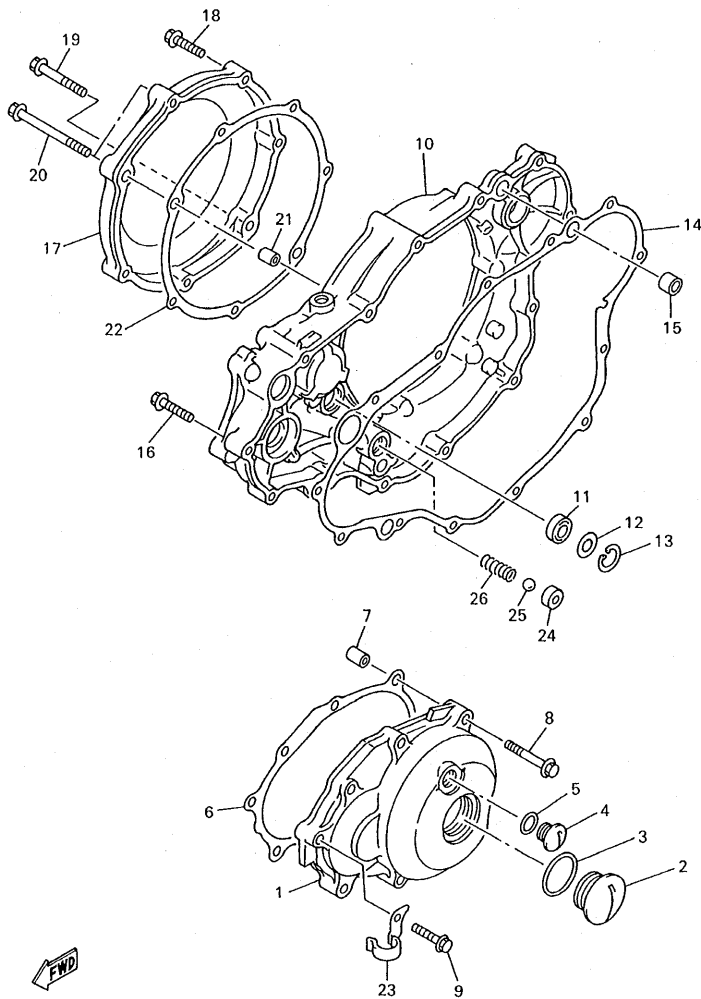

FIG. 13 CRANKCASE COVER 1

REF. NO.	PART NO.	DESCRIPTION					REMARKS
			5UG1	5UG2	5UG3	5UG4	
1	5BE-15411-00	COVER, CRANKCASE 1	1	1	1	1	
2	90340-32123	PLUG, STRAIGHT SCREW	1	1	1	1	
3	93210-32172	O-RING	1	1	1	1	
4	90340-14128	PLUG, STRAIGHT SCREW	1	1	1	1	
5	93210-14369	O-RING	1	1	1	1	
6	5BE-15451-00	GASKET, CRANKCASE COVER 1	1	1	1	1	
7	99530-08016	PIN, DOWEL	2	2	2	2	
8	95027-06040	BOLT, FLANGE	2	2	2	2	
9	95027-06030	BOLT, FLANGE	6	6	6	6	
10	5JG-15431-00	COVER, CRANKCASE 3	1	1	1	1	
11	93101-14164	OIL SEAL	1	1	1	1	
12	90201-15701	WASHER, PLATE (1.0T)	1	1	1	1	
13	99009-22500	CIRCLIP	1	1	1	1	
14	5BE-15462-00	GASKET, CRANKCASE COVER 3	1	1	1	1	
15	91812-16001	PIN, DOWEL	2	2	2	2	
16	95027-06030	BOLT, FLANGE	10	10	10	10	
17	5JG-15415-00	COVER, GENERATOR	1	1	1	1	
18	95027-06030	BOLT, FLANGE	4	4	4	4	
19	95027-06040	BOLT, FLANGE	1	1	1	1	
20	90105-065A1	BOLT, WASHER BASED	2	2	2	2	
21	99530-08016	PIN, DOWEL	2	2	2	2	
22	5JG-15453-00	GASKET, CARBURETOR COVER	1	1	1	1	
23	90462-10241	CLAMP	1	1	1	1	
24	583-13113-00	SEAT, CHECK BALL	1	1	1	1	
25	93503-08007	BALL	1	1	1	1	
26	90501-043E0	SPRING, COMPRESSION	1	1	1	1	



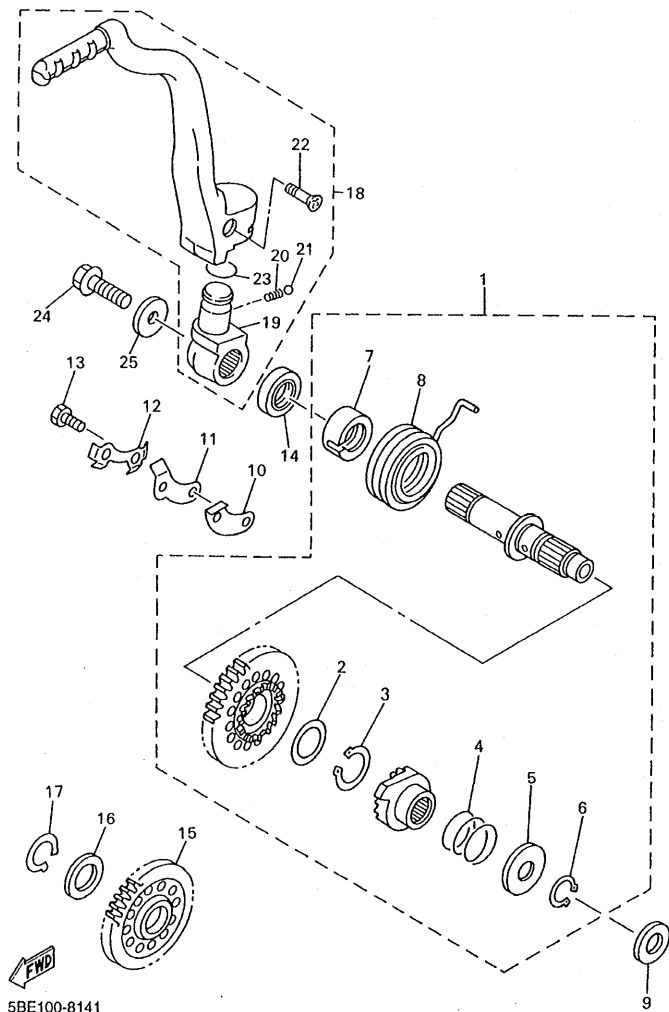
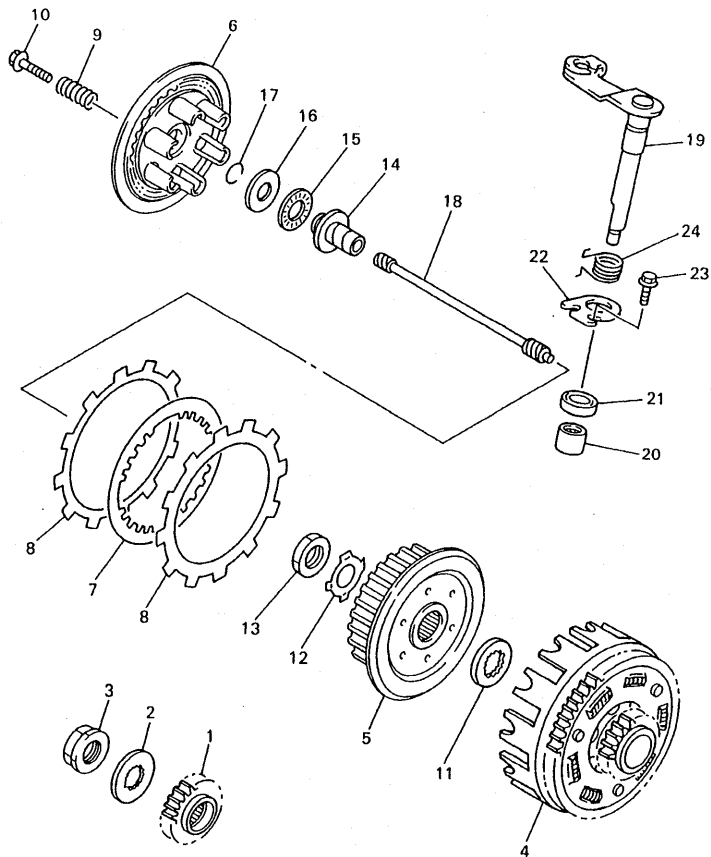

FIG. 14 STARTER

REF. NO.	PART NO.	DESCRIPTION	SUG1	SUG2	SUG3	SUG4	REMARKS
1	5GR-15601-00	KICK SHAFT ASSY	1	1	1	1	
2	90201-20685	.WASHER, PLATE (0.5T)	1	1	1	1	
3	93410-20038	.CIRCLIP	1	1	1	1	
4	90501-16107	.SPRING, COMPRESSION	1	1	1	1	
5	90201-167P7	.WASHER, PLATE	1	1	1	1	
6	99009-16400	.CIRCLIP	1	1	1	1	
7	5GR-15664-00	.GUIDE, SPRING	1	1	1	1	
8	90508-30743	.SPRING, TORSION	1	1	1	1	
9	90201-162H4	WASHER, PLATE	1	1	1	1	
10	5BE-15668-00	STOPPER	1	1	1	1	
11	5BE-15674-00	GUIDE, RATCHET WHEEL	1	1	1	1	
12	5BE-15686-01	WASHER, LOCK	1	1	1	1	
13	90101-06001	BOLT	2	2	2	2	
14	93102-20108	OIL SEAL	1	1	1	1	
15	5BE-15651-00	GEAR, KICK IDLE	1	1	1	1	
16	90201-20276	WASHER, PLATE (1.0T)	1	1	1	1	
17	99009-20400	CIRCLIP	1	1	1	1	
18	5BE-15620-02	KICK CRANK ASSY	1	1	1	1	
19	3SP-15621-02	.BOSS, KICK CRANK	1	1	1	1	
20	90501-13720	.SPRING, COMPRESSION	1	1	1	1	
21	93501-04011	.BALL	1	1	1	1	
22	90152-06010	.SCREW, COUNTERSUNK	1	1	1	1	
23	93210-19216	.O-RING	1	1	1	1	
24	90105-08752	BOLT, WASHER BASED	1	1	1	1	
25	90201-087A9	WASHER, PLATE	1	1	1	1	



5JG1100-0150

FIG. 15 CLUTCH

REF. NO.	PART NO.	DESCRIPTION	5JG1	5JG2	5JG3	5JG4	REMARKS
1	5JG-16111-00	GEAR, PRIMARY DRIVE	1	1	1	1	
2	90215-21001	WASHER, LOCK	1	1	1	1	
3	90179-20001	NUT	1	1	1	1	
* 4	5JG-16150-01	PRIMARY DRIVEN GEAR COMP.	1	1	1	1	
5	5JG-16371-00	BOSS, CLUTCH	1	1	1	1	
6	5JG-16351-00	PLATE, PRESSURE 1	1	1	1	1	
7	5JG-16325-00	PLATE, CLUTCH 2	8	8	8	8	
8	3XK-16321-00	PLATE, FRICTION	9	9	9	9	
9	90501-244L9	SPRING, COMPRESSION	6	6	6	6	
10	90159-06092	SCREW, WITH WASHER	6	6	6	6	
11	2JN-16154-00	PLATE, THRUST 1	1	1	1	1	
12	90215-20231	WASHER, LOCK	1	1	1	1	
13	90170-20327	NUT	1	1	1	1	
14	5BE-16356-00	ROD, PUSH 1	1	1	1	1	
15	93340-21505	BEARING	1	1	1	1	
16	90201-125L6	WASHER, PLATE	1	1	1	1	
17	93440-10085	CIRCLIP	1	1	1	1	
18	5JG-16357-00	ROD, PUSH 2	1	1	1	1	
19	5BE-16381-00	PUSH LEVER COMP.	1	1	1	1	
20	93315-11206	BEARING	1	1	1	1	
21	93102-12224	OIL SEAL	1	1	1	1	
22	4JT-16384-00	PLATE, SEAT	1	1	1	1	
23	95027-06010	BOLT, FLANGE	1	1	1	1	
24	90508-142B5	SPRING, TORSION	1	1	1	1	

FIG. 16 TRANSMISSION

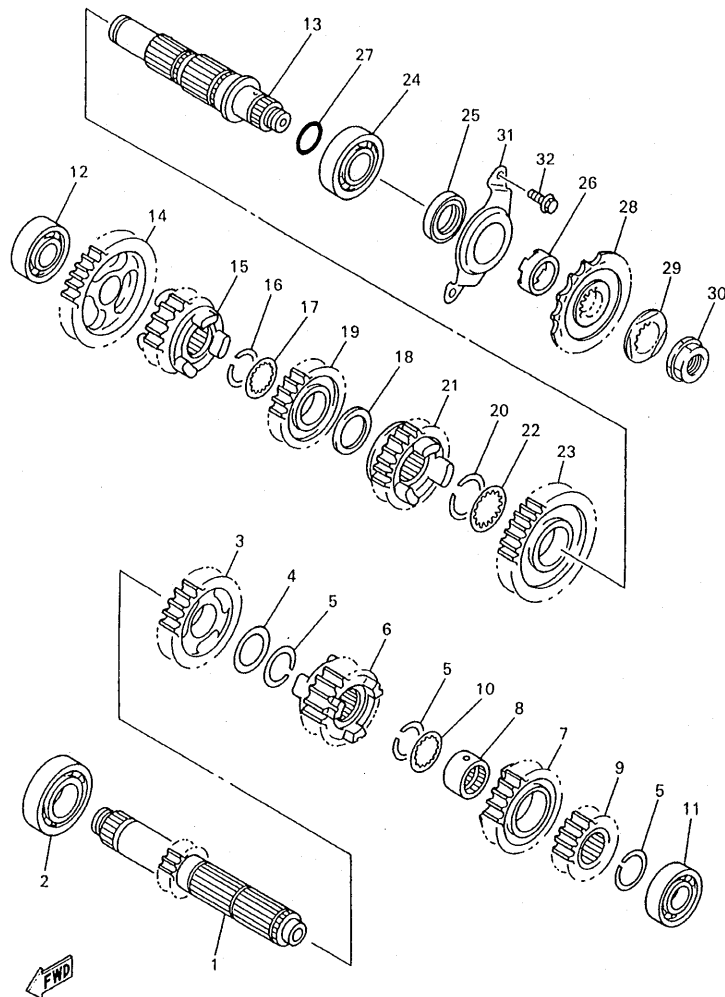

5JG1100-0160

REF. NO.	PART NO.	DESCRIPTION					REMARKS
			5JG1	5JG2	5JG3	5JG4	
1	5JG-17411-00	AXLE, MAIN	1	1	1	1	
2	93306-20532	BEARING	1	1	1	1	
3	5BE-17151-00	GEAR, 5TH PINION	1	1	1	1	
4	90201-253K0	WASHER, PLATE (T=1.0)	1	1	1	1	
5	93440-25084	CIRCLIP	3	3	3	3	
6	5BE-17131-10	GEAR, 3RD PINION	1	1	1	1	
7	5BE-17141-20	GEAR, 4TH PINION	1	1	1	1	
8	90387-2113G	COLLAR	1	1	1	1	
9	5JG-17121-00	GEAR, 2ND PINION	1	1	1	1	
10	90209-21332	WASHER	1	1	1	1	
11	93306-00431	BEARING	1	1	1	1	
12	93306-00426	BEARING	1	1	1	1	
13	5BE-17421-00	AXLE, DRIVE	1	1	1	1	
14	5JG-17211-00	GEAR, 1ST WHEEL	1	1	1	1	
15	5BE-17251-10	GEAR, 5TH WHEEL	1	1	1	1	
16	93440-25084	CIRCLIP	1	1	1	1	
17	90209-21332	WASHER	1	1	1	1	
18	90201-253K0	WASHER, PLATE (T=1.0)	1	1	1	1	
19	5BE-17231-00	GEAR, 3RD WHEEL	1	1	1	1	
20	93440-28062	CIRCLIP	1	1	1	1	
21	5BE-17241-10	GEAR, 4TH WHEEL	1	1	1	1	
22	90209-26348	WASHER	1	1	1	1	
23	5JG-17221-00	GEAR, 2ND WHEEL	1	1	1	1	
24	93306-20593	BEARING	1	1	1	1	
25	93102-32480	OIL SEAL	1	1	1	1	
26	90387-2513F	COLLAR	1	1	1	1	
27	93210-22298	O-RING	1	1	1	1	

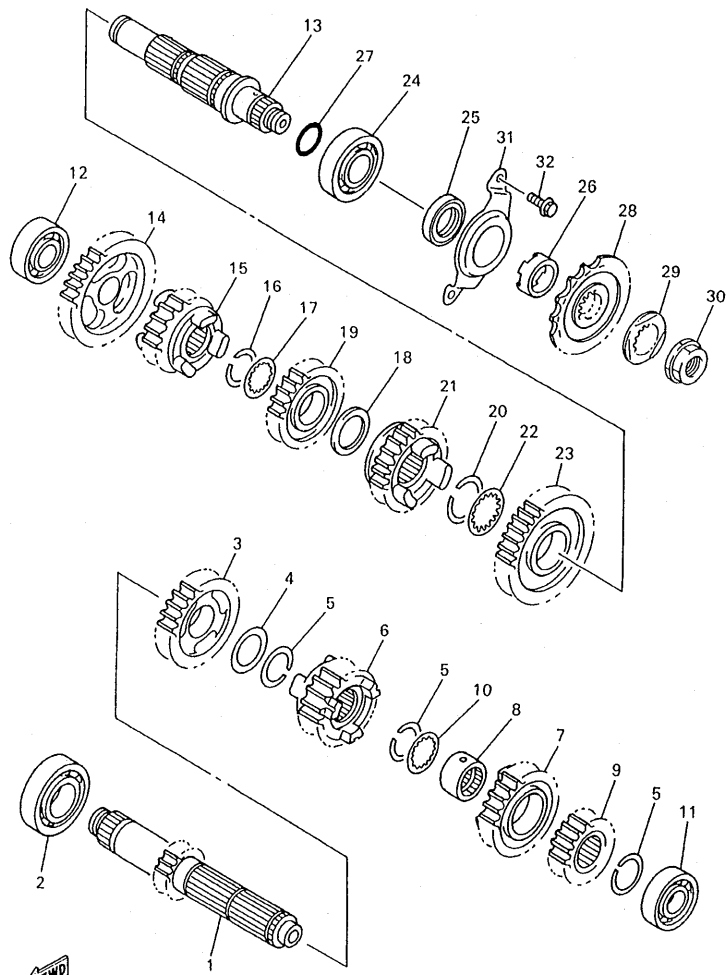

5JG1100-0160

FIG. 16 TRANSMISSION

REF. NO.	PART NO.	DESCRIPTION	5JG1	5JG2	5JG3	5JG4	REMARKS
28	9383E-14215	SPROCKET, DRIVE (14T)	1	1	1	1	
29	90215-21001	WASHER, LOCK	1	1	1	1	
30	90179-20001	NUT	1	1	1	1	
31	5GR-17471-00	PLATE, COVER	1	1	1	1	
32	90105-06553	BOLT, WASHER BASED	2	2	2	2	
-----							
-----							
-----							
-----							
-----							
-----							
-----							
-----							
-----							

FIG. 17 SHIFT CAM. FORK

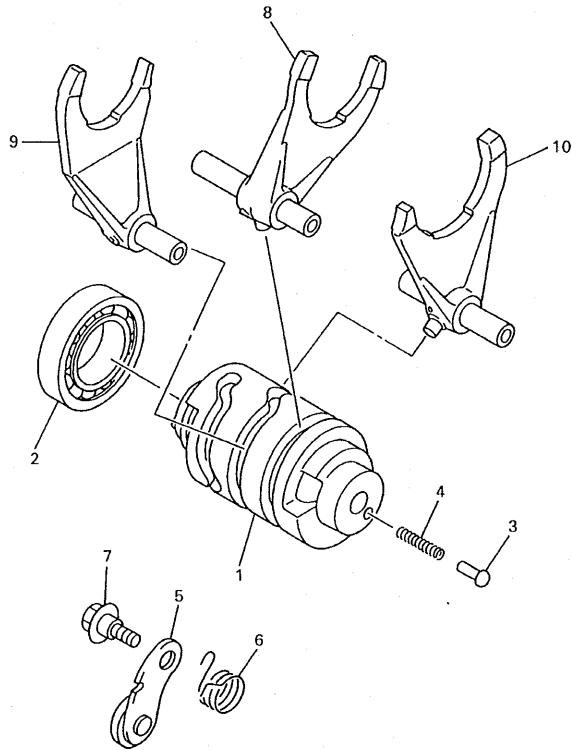

REF. NO.	PART NO.	DESCRIPTION					REMARKS
			5JG1	5JG2	5JG3	5JG4	
1	5BE-18541-00	CAM, SHIFT	1	1	1	1	
2	93306-90501	BEARING	1	1	1	1	
3	4BA-18542-00	POINT, NEUTRAL	1	1	1	1	
4	90501-06022	SPRING, COMPRESSION	1	1	1	1	
5	3XK-18140-00	STOPPER LEVER ASSY	1	1	1	1	
6	90508-26561	SPRING, TORSION	1	1	1	1	
7	90109-063F8	BOLT	1	1	1	1	
8	5BE-18501-00	FORK, SHIFT 1	1	1	1	1	
9	5BE-18502-10	FORK, SHIFT 2	1	1	1	1	
10	5BE-18503-00	FORK, SHIFT 3	1	1	1	1	



5BE100-8170

FIG. 18 SHIFT SHAFT

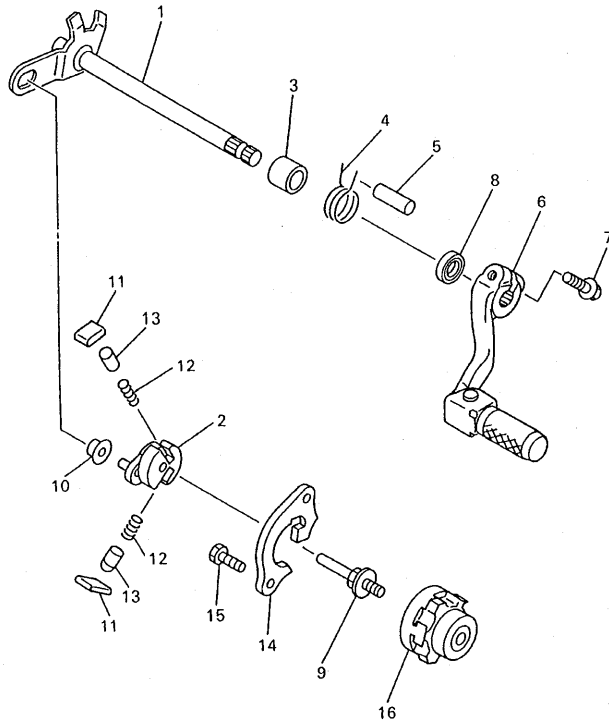

FWD

5BE100-8180

REF. NO.	PART NO.	DESCRIPTION					REMARKS
			5JG1	5JG2	5JG3	5JG4	
1	3XK-18101-02	SHIFT SHAFT ASSY	1	1	1	1	
2	3XK-18122-00	LEVER, SHIFT 2	1	1	1	1	
3	90387-124F4	COLLAR	1	1	1	1	
4	90508-291A8	SPRING, TORSION	1	1	1	1	
5	93608-33046	PIN, DOWEL	1	1	1	1	
6	5BE-18110-00	SHIFT PEDAL ASSY	1	1	1	1	
7	95027-06020	BOLT, FLANGE	1	1	1	1	
8	93102-12106	OIL SEAL (SD 12-22-5 HS)	1	1	1	1	
9	3XJ-18173-00	PIN, SHIFT	1	1	1	1	
10	3XJ-18178-00	ROLLER, SHIFT LEVER	1	1	1	1	
11	3XJ-18182-00	PAWL, SHIFTER	2	2	2	2	
12	90501-052G5	SPRING, COMPRESSION	2	2	2	2	
13	3XJ-18184-00	PIN, PAWL	2	2	2	2	
14	5BE-18172-00	GUIDE, SHIFT	1	1	1	1	
15	90101-06664	BOLT	2	2	2	2	
16	4EW-18185-00	SEGMENT	1	1	1	1	

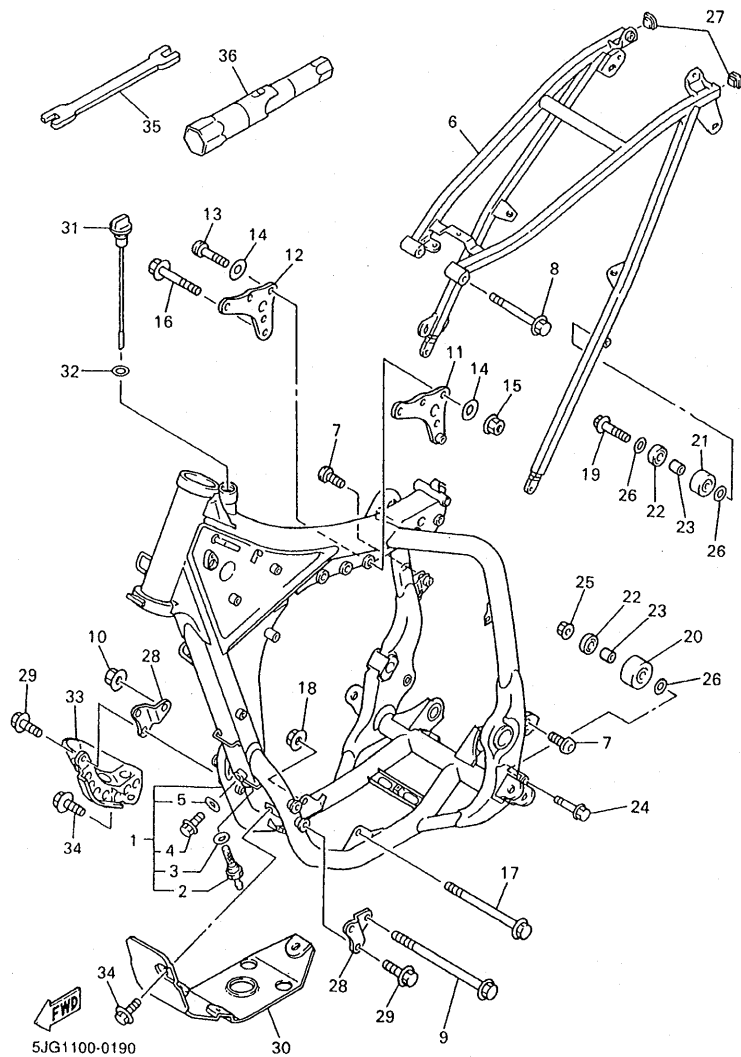

FIG. 19 FRAME

REF. NO.	PART NO.	DESCRIPTION					REMARKS
			5JG1	5JG2	5JG3	5JG4	
1	5JG-21110-00-P0	FRAME COMP.	1	1	1	1	DPBMC
2	5BE-21756-00	.NET, FILTER	1	1	1	1	
3	90430-18130	.GASKET	1	1	1	1	
4	95827-08012	.BOLT, FLANGE	1	1	1	1	
5	90430-08119	.GASKET	1	1	1	1	
6	5JG-21190-00-P0	REAR FRAME COMP.	1	1	1	1	DPBMC
7	90110-08096	BOLT, HEXAGON SOCKET HEAD	2	2	2	2	
8	90105-08099	BOLT, WASHER BASED	1	1	1	1	
9	95817-10160	BOLT, FLANGE	1	1	1	1	
10	95807-10200	NUT, SELF-LOCKING	1	1	1	1	
11	5GR-21425-01	BRACKET, REAR UPPER 1	1	1	1	1	
12	5BE-21425-01	BRACKET, REAR UPPER 1	1	1	1	1	
13	92017-08055	BOLT, BUTTON HEAD	3	3	3	3	
14	90201-086P8	WASHER, PLATE	6	6	6	6	
15	90185-08169	NUT, SELF-LOCKING	3	3	3	3	
16	95817-10050	BOLT, FLANGE	1	1	1	1	
17	90105-10733	BOLT, WASHER BASED	1	1	1	1	
18	95807-10200	NUT, SELF-LOCKING	1	1	1	1	
19	95027-08040	BOLT, FLANGE	1	1	1	1	
20	3JD-22178-10	TENSIONER	1	1	1	1	
21	4EW-22178-00	TENSIONER	1	1	1	1	
22	93300-60804	BEARING	2	2	2	2	
23	90387-086N4	COLLAR	2	2	2	2	
24	95027-08065	BOLT, FLANGE	1	1	1	1	
25	95707-08500	NUT, FLANGE	1	1	1	1	
26	90201-086P8	WASHER, PLATE	3	3	3	3	
27	90338-16148	PLUG	2	2	2	2	





FIG. 20 FENDER

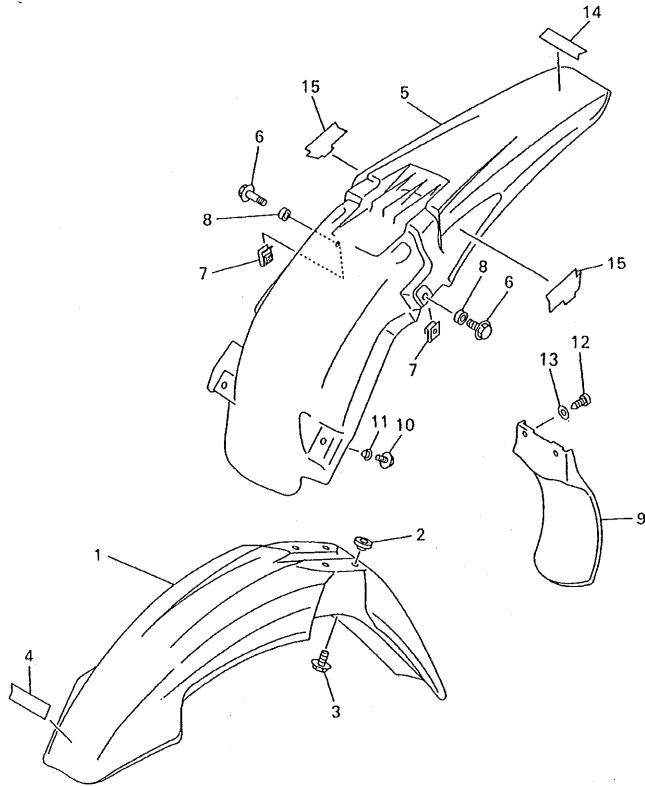

REF. NO.	PART NO.	DESCRIPTION	5JG1	5JG2	5JG3	5JG4	REMARKS
1	5HD-21511-00	FENDER, FRONT	1	1	1	1	
2	3JD-21748-00	COLLAR	4	4	4	4	
3	90119-06096	BOLT, WITH WASHER	4	4	4	4	
4	99241-00080	EMBLEM, YAMAHA	1	1	1	1	
5	5BE-21611-10	FENDER, REAR	1	1	1	1	
6	90105-06553	BOLT, WASHER BASED	2	2	2	2	
7	90183-06023	NUT, SPRING	2	2	2	2	
8	90387-0701A	COLLAR	2	2	2	2	
9	5BE-21642-00	GUARD, FLAP	1	1	1	1	
10	90105-06690	BOLT, WASHER BASED	2	2	2	2	
11	90387-06009	COLLAR	2	2	2	2	
12	97707-60016	SCREW, TAPPING	2	2	2	2	
13	90201-06557	WASHER, PLATE	2	2	2	2	
14	99241-00080	EMBLEM, YAMAHA	1	1	1	1	EXCEPT FOR CAN
15	5JG-2163G-00	EMBLEM 1	2	2	2	2	



5JG1100-0200

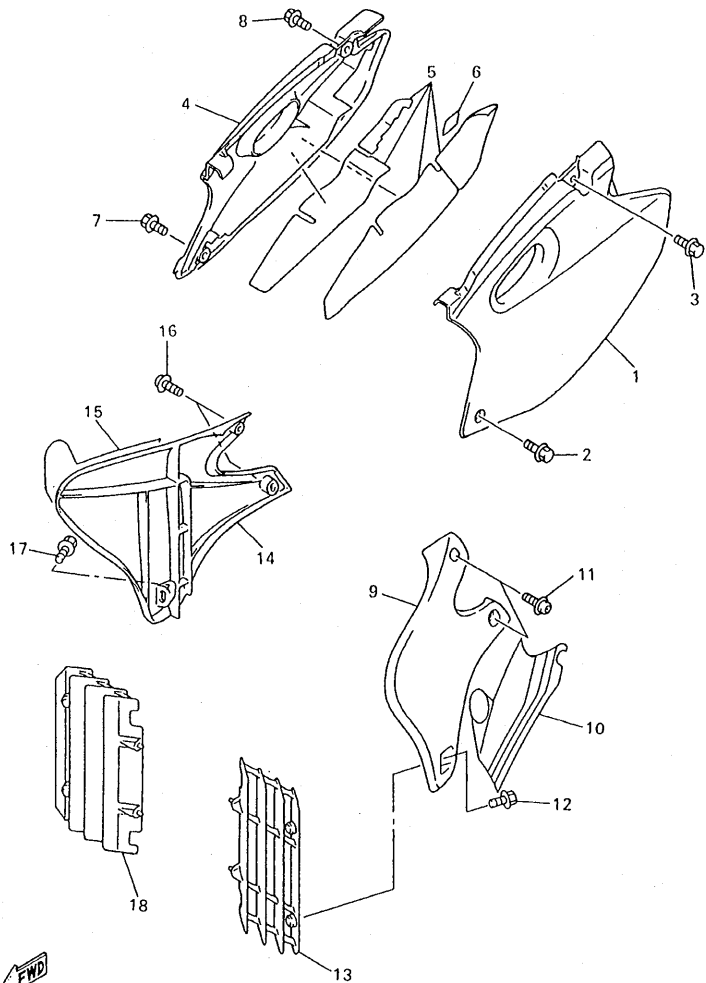

5JG1100-0210

FIG. 21 SIDE COVER

REF. NO.	PART NO.	DESCRIPTION	SJG1	SJG2	SJG3	SJG4	REMARKS
1	5BE-21711-00	COVER, SIDE 1	1	1	1	1	
2	95827-06016	BOLT, FLANGE	1	1	1	1	
3	90119-08238	BOLT, WITH WASHER	1	1	1	1	
4	5BE-21721-00	COVER, SIDE 2	1	1	1	1	
5	5BE-2174A-00	INSULATOR, SIDE COVER	1	1	1	1	
6	3FY-21575-01	SEAL 1	1	1	1	1	
7	95827-06016	BOLT, FLANGE	1	1	1	1	
8	90119-08238	BOLT, WITH WASHER	1	1	1	1	
9	5JG-21731-00	COVER, SIDE 3	1	1	1	1	
10	5JG-2173E-00	GRAPHIC 1	1	1	1	1	
11	90159-06182	SCREW, WITH WASHER	2	2	2	2	
12	90159-06078	SCREW, WITH WASHER	1	1	1	1	
13	5JG-2172A-00	PANEL 1	1	1	1	1	
14	5JG-21741-00	COVER, SIDE 4	1	1	1	1	
15	5JG-2173F-00	GRAPHIC 2	1	1	1	1	
16	90159-06182	SCREW, WITH WASHER	2	2	2	2	
17	90159-06078	SCREW, WITH WASHER	1	1	1	1	
18	5JG-2172A-00	PANEL 1	1	1	1	1	

FIG. 22 REAR ARM

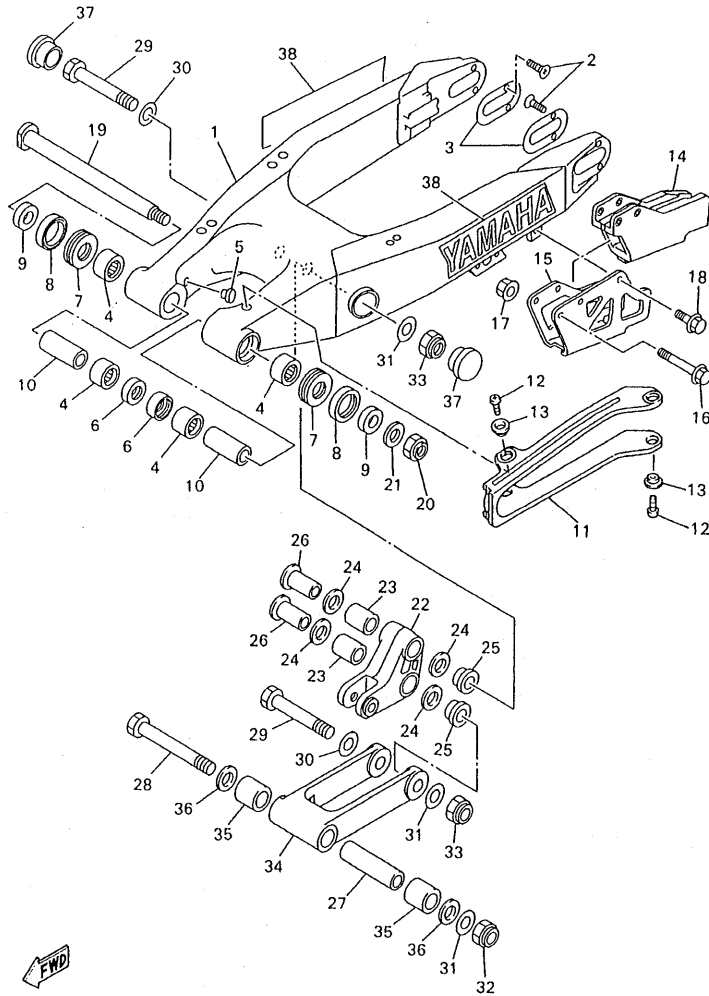

5JG1100-0220

REF. NO.	PART NO.	DESCRIPTION					REMARKS
			5JG1	5JG2	5JG3	5JG4	
1	5CU-22110-00	REAR ARM COMP.	1	1	1	1	
2	90151-04048	SCREW, COUNTERSUNK	4	4	4	4	
3	5ET-22355-00	PATCH	2	2	2	2	
4	93317-22262	BEARING	4	4	4	4	
5	90338-16148	PLUG	2	2	2	2	
6	93106-22019	OIL SEAL (DC 22-28-8)	2	2	2	2	
7	93342-22217	BEARING	2	2	2	2	
8	93109-28043	OIL SEAL	2	2	2	2	
9	90387-1714R	COLLAR	2	2	2	2	
10	90387-1714S	COLLAR	2	2	2	2	
11	5JG-22151-00	SEAL, GUARD	1	1	1	1	
12	98507-05008	SCREW, PAN HEAD	4	4	4	4	
13	5JG-22156-00	WASHER, PLATE	4	4	4	4	
14	4XM-22199-00	SUPPORT, CHAIN	1	1	1	1	
15	4XM-22128-00	COVER, THRUST 1	1	1	1	1	
16	95027-06050	BOLT, FLANGE	2	2	2	2	
17	90179-06568	NUT	2	2	2	2	
18	95027-06010	BOLT, FLANGE	1	1	1	1	
19	5DH-22141-00	SHAFT, PIVOT	1	1	1	1	
20	90185-16127	NUT, SELF-LOCKING	1	1	1	1	
21	90201-164H4	WASHER, PLATE	1	1	1	1	
22	5ET-2217A-00	ARM, RELAY	1	1	1	1	
23	93315-32056	BEARING	2	2	2	2	
24	93109-20076	OIL SEAL	4	4	4	4	
25	90387-164N2	COLLAR	2	2	2	2	
26	90387-164N3	COLLAR	2	2	2	2	
27	90387-167Y9	COLLAR	1	1	1	1	

D3

FIG. 22 REAR ARM

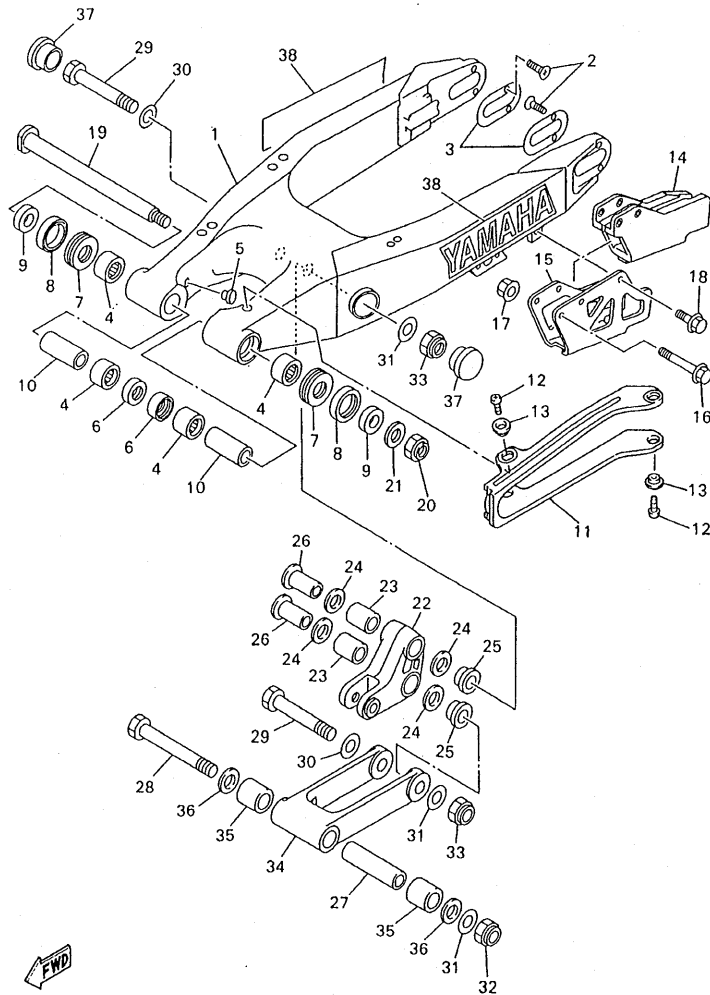

5JG1100-0220

REF. NO.	PART NO.	DESCRIPTION					REMARKS
			5JG1	5JG2	5JG3	5JG4	
28	90109-147F2	BOLT	1	1	1	1	
29	90109-142F4	BOLT	2	2	2	2	
30	90201-164H4	WASHER, PLATE	2	2	2	2	
31	90201-14740	WASHER, PLATE	3	3	3	3	
32	90185-14112	NUT, SELF-LOCKING	1	1	1	1	
33	95617-14100	NUT, U	2	2	2	2	
34	5DH-2217F-01	ROD, CONNECTING 1	1	1	1	1	
35	93315-32056	BEARING	2	2	2	2	
36	93109-20076	OIL SEAL	2	2	2	2	
37	5HD-2135F-00	COVER	2	2	2	2	
38	99244-00200	EMBLEM, YAMAHA	2	2	2	2	

FIG. 23 REAR SUSPENSION

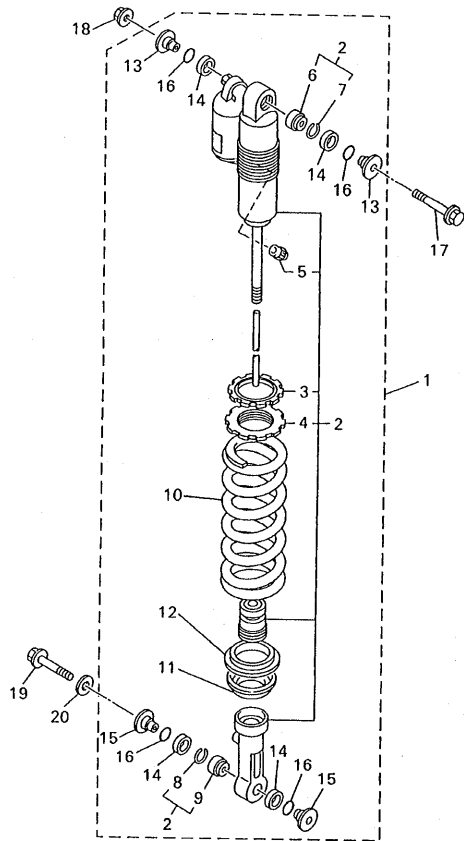

5GR100-9230

REF. NO.	PART NO.	DESCRIPTION	SJG1	SJG2	SJG3	SJG4	REMARKS
1	5JG-22210-00	SHOCK ABSORBER ASSY, REAR	1				
	5JG-22210-10	SHOCK ABSORBER ASSY, REAR		1			
	5JG-22210-20	SHOCK ABSORBER ASSY, REAR			1		
	5JG-22210-30	SHOCK ABSORBER ASSY, REAR				1	UR FOR CAN
	5JG-22210-40	SHOCK ABSORBER ASSY, REAR				1	UR
2	5JG-22201-00	.DAMPER SUB ASSY	1				
	5JG-22201-10	.DAMPER SUB ASSY		1			
	5JG-22201-20	.DAMPER SUB ASSY			1		
	5JG-22201-30	.DAMPER SUB ASSY				1	UR FOR CAN
	5JG-22201-40	.DAMPER SUB ASSY				1	UR
3	3SP-22234-00	.GUIDE, SPRING 3	1	1	1	1	
4	3SP-22213-00	.SEAT, SPRING UPPER	1	1	1	1	
5	509-23184-L0	.CAP, AIR VALVE	1	1	1	1	
6	4JX-22226-00	.BUSH, SHOCK ABSORBER LOWER	1	1	1	1	
7	5DH-23183-00	.CIRCLIP	1	1	1	1	
8	5DH-23183-00	.CIRCLIP	1	1	1	1	
9	4JX-22226-00	.BUSH, SHOCK ABSORBER LOWER	1	1	1	1	
10	5DH-22212-50	.SPRING (K=5.4)	1		1	1	
	5ET-22212-40	.SPRING (K=APPROX.5.4)			1		
11	5DH-22214-00	.GUIDE, SPRING 1	1	1	1	1	
12	5DH-22224-00	.GUIDE, SPRING 2	1	1	1	1	
13	5DH-22253-00	.COLLAR, DISTANCE	2	2	2	2	
14	3JE-22475-00	.SEAL, DUST	4	4	4	4	
15	4EW-22253-00	.COLLAR, DISTANCE	2	2	2	2	
16	4EW-22474-00	.SEAL, RING	4	4	4	4	
17	90105-10323	BOLT, WASHER BASED	1	1	1	1	
18	95607-10200	NUT, SELF-LOCKING	1	1	1	1	

FIG. 23 REAR SUSPENSION

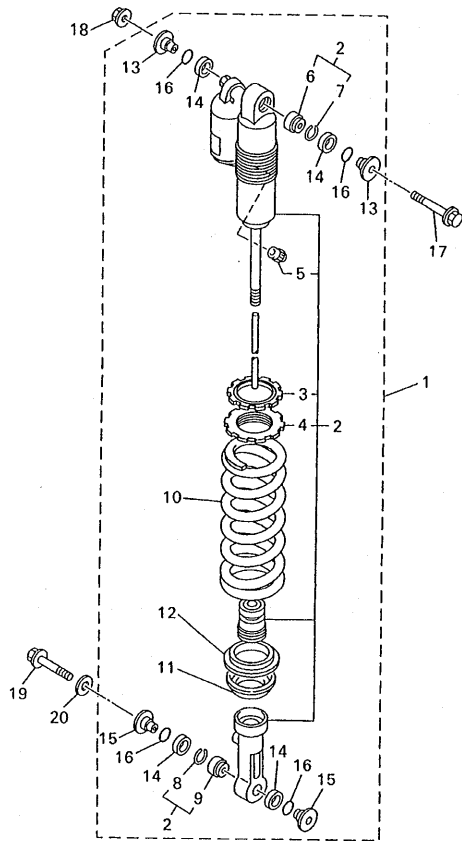

REF. NO.	PART NO.	DESCRIPTION	5/G1	5/G2	5/G3	5/G4	REMARKS
19	90105-105A2	BOLT, WASHER BASED	1	1	1	1	
20	90201-112U6	WASHER, PLATE	1	1	1	1	

  
5GR100-9230

**D6**

FIG. 24 STEERING

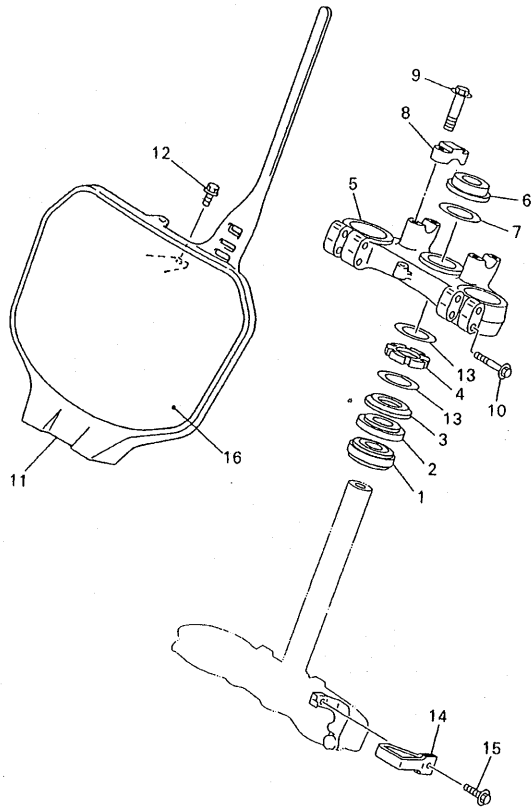

REF. NO.	PART NO.	DESCRIPTION	5JG1	5JG2	5JG3	5JG4	REMARKS
1	93332-00081	BEARING	1	1	1	1	
2	93332-00068	BEARING	1	1	1	1	
3	4EW-23416-00	COVER, BALL RACE 2	1	1	1	1	
4	90179-28650	NUT	1	1	1	1	
5	5HC-23435-10	CROWN, HANDLE	1	1	1	1	
6	90170-24373	NUT	1	1	1	1	
7	90201-247L2	WASHER, PLATE	1	1	1	1	
8	3SP-23441-00	HOLDER, HANDLE UPPER	2	2	2	2	
9	95027-08035	BOLT, FLANGE	4	4	4	4	
10	95027-08040	BOLT, FLANGE	4	4	4	4	
11	5HD-23485-00	PLATE, NUMBER	1	1	1	1	
12	95027-06014	BOLT, FLANGE	1	1	1	1	
13	90201-286K9	WASHER, PLATE	2	2	2	2	
14	4DA-23389-00	GUIDE, CABLE	1	1	1	1	
15	90119-05071	BOLT, WITH WASHER	1	1	1	1	
16	5HD-2339E-00	GRAPHIC 1	1	1	1	1	



5JG1100-0240

FIG. 25 FRONT FORK

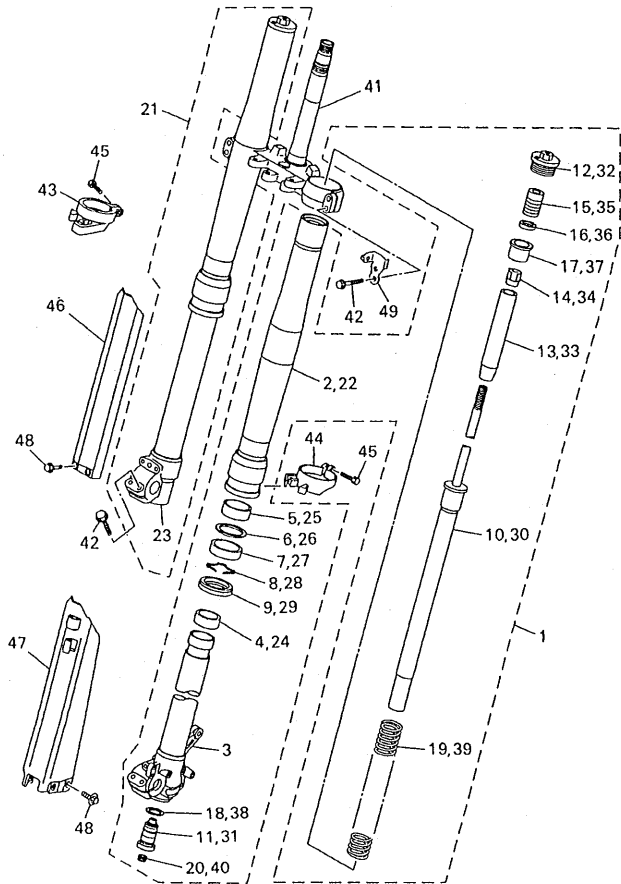

REF. NO.	PART NO.	DESCRIPTION	5JG1	5JG2	5JG3	5JG4	REMARKS
1	5JG-23102-L0	FRONT FORK ASSY (L.H)	1		1	1	
	5JG-23102-M0	FRONT FORK ASSY (L.H)		1			
2	5HD-23136-L0	.TUBE, OUTER (RIGHT)	1	1	1	1	
3	5DH-23120-L0	.INNER TUBE COMP.2	1	1	1	1	
4	5ET-23171-L0	.PISTON, FRONT FORK	1	1	1	1	
5	5ET-23125-L0	.METAL, SLIDE 1	1	1	1	1	
6	4SS-23146-L0	.WASHER, OIL SEAL	1	1	1	1	
7	5ET-23145-L0	.OIL SEAL	1	1	1	1	
8	4SS-23153-L0	.RING, SNAP	1	1	1	1	
9	5HD-23144-L0	.SEAL, DUST	1	1	1	1	
10	5JG-23170-L0	.CYLINDER COMP., FRONT FORK	1		1	1	
	5JG-23170-M0	.CYLINDER COMP., FRONT FORK		1			
11	5JG-2316A-L0	.VALVE COMP.	1		1	1	
	5JG-2316A-M0	.VALVE COMP.		1			
12	5HD-23111-L0	.BOLT, CAP	1	1	1	1	
13	5DH-23142-L0	.SEAT, SPRING UPPER	1	1	1	1	
14	5HD-23393-L0	.NUT, SPECIAL	1	1	1	1	
15	5DH-23195-L0	.RUBBER	1	1	1	1	
16	5DH-23149-L0	.WASHER, SPRING UPPER	1	1	1	1	
17	5DH-23118-L0	.SPACER	1	1	1	1	
18	4SS-23158-L0	.GASKET	1	1	1	1	
19	5GR-23141-L0	.SPRING, FRONT FORK (K=0.46)	1		1	1	
	5BE-23141-L0	.SPRING, FRONT FORK (K=0.45)		1			
20	3JD-2312G-L0	.PLUG	1	1	1	1	
21	5JG-23103-L0	FRONT FORK ASSY (R.H)	1		1	1	
	5JG-23103-M0	FRONT FORK ASSY (R.H)		1			
22	5HD-23136-L0	.TUBE, OUTER (RIGHT)	1	1	1	1	



5JG1100-0250

D8



FIG. 25 FRONT FORK

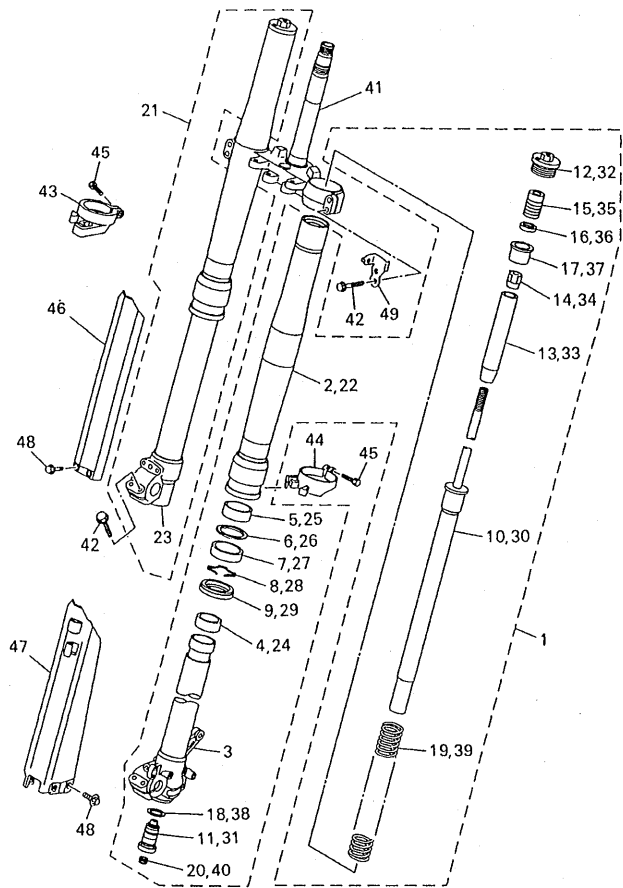

REF. NO.	PART NO.	DESCRIPTION	5JG1	5JG2	5JG3	5JG4	REMARKS
23	5BF-23110-L0	.INNER TUBE COMP.1	1	1	1	1	
24	5ET-23171-L0	.PISTON, FRONT FORK	1	1	1	1	
25	5ET-23125-L0	.METAL, SLIDE 1	1	1	1	1	
26	4SS-23146-L0	.WASHER, OIL SEAL	1	1	1	1	
27	5ET-23145-L0	.OIL SEAL	1	1	1	1	
28	4SS-23153-L0	.RING, SNAP	1	1	1	1	
29	5HD-23144-L0	.SEAL, DUST	1	1	1	1	
30	5JG-23170-L0	.CYLINDER COMP., FRONT FORK	1		1	1	
	5JG-23170-M0	.CYLINDER COMP., FRONT FORK		1			
31	5JG-2316A-L0	.VALVE COMP.	1		1	1	
	5JG-2316A-M0	.VALVE COMP.		1			
32	5HD-23111-L0	.BOLT, CAP	1	1	1	1	
33	5DH-23142-L0	.SEAT, SPRING UPPER	1	1	1	1	
34	5HD-23393-L0	.NUT, SPECIAL	1	1	1	1	
35	5DH-23195-L0	.RUBBER	1	1	1	1	
36	5DH-23149-L0	.WASHER, SPRING UPPER	1	1	1	1	
37	5DH-23118-L0	.SPACER	1	1	1	1	
38	4SS-23158-L0	.GASKET	1	1	1	1	
39	5GR-23141-L0	.SPRING, FRONT FORK (K=0.46)	1		1	1	
	5BE-23141-L0	.SPRING, FRONT FORK (K=0.45)		1			
40	3JD-2312G-L0	.PLUG	1	1	1	1	
41	5HC-23340-L0	UNDER BRACKET COMP.	1	1	1	1	
42	95021-08040	BOLT, FLANGE	8	8	8	8	
43	4SS-2314G-L0	PROTECTOR GUIDE COMP., 2	1	1	1	1	
44	5DH-2314F-L0	PROTECTOR GUIDE COMP., 1	1	1	1	1	
45	4SS-23346-L0	BOLT 1	2	2	2	2	
46	5DH-2314J-00	PROTECTOR COMP., 2	1	1	1	1	



5JG1100-0250

D9

FIG. 25 FRONT FORK

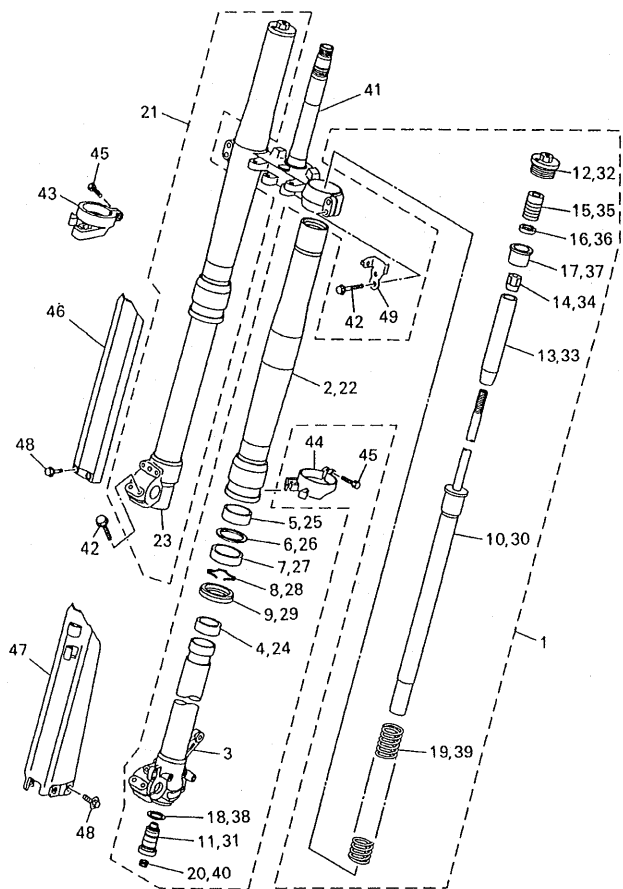

REF. NO.	PART NO.	DESCRIPTION					REMARKS
			5JG1	5JG2	5JG3	5JG4	
47	5DH-2314H-00	PROTECTOR COMP., 1	1	1	1	1	
48	3SP-23356-L0	BOLT 2	6	6	6	6	
49	5HC-2331E-00	GUIDE, CABLE	1	1	1	1	

 5JG1100-0250

FIG. 26 FUEL TANK

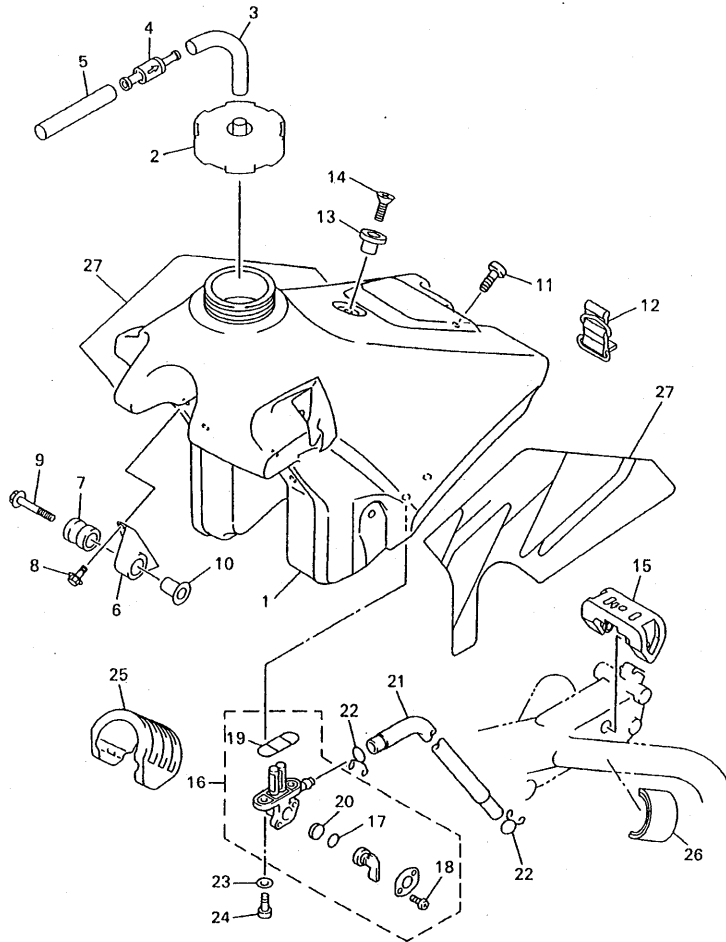

5JG1100-0260

REF. NO.	PART NO.	DESCRIPTION	5JG1	5JG2	5JG3	5JG4	REMARKS
* 1	5JG-24110-00	FUEL TANK COMP.	1	1	1	1	
2	1UY-24610-00	CAP ASSY	1	1	1	1	
3	90445-09220	HOSE	1	1	1	1	
4	3XJ-24380-00	PIPE JOINT ASSY	1	1	1	1	
5	90445-09100	HOSE	1	1	1	1	
6	24X-24144-00	HOLDER, DAMPER	2	2	2	2	
7	90480-18549	GROMMET	2	2	2	2	
8	95027-06016	BOLT, FLANGE	4	4	4	4	
9	90119-06214	BOLT, WITH WASHER	2	2	2	2	
10	3JD-24186-00	WASHER, SPECIAL	2	2	2	2	
11	98907-06020	SCREW, BIND	1	1	1	1	
12	3SP-24173-00	BAND, TANK FITTING 1	1	1	1	1	
13	4EW-2412F-00	BRACKET, SEAT	1	1	1	1	
14	98707-06025	SCREW, FLAT HEAD	1	1	1	1	
15	4SS-24181-00	DAMPER, LOCATING 1	1	1	1	1	
16	4DP-24500-00	FUEL COCK ASSY 1	1	1	1	1	
17	3AJ-24534-00	.SEAL, COCK	1	1	1	1	
18	97801-03008	.SCREW, PAN HEAD	2	2	2	2	
19	4X8-24512-00	.O-RING	1	1	1	1	
20	3AJ-24523-00	.VALVE PACKING	1	1	1	1	
21	90445-11002	HOSE	1	1	1	1	
22	90467-10008	CLIP	2	2	2	2	
23	90202-05193	WASHER, PLATE	2	2	2	2	
24	90149-06011	SCREW	2	2	2	2	
25	5BE-24182-00	DAMPER, LOCATING 2	1	1	1	1	
26	3V6-22358-00	SEAL 1	2	2	2	2	
27	5JG-24240-00	GRAPHIC SET	1	1	1	1	

FIG. 27 SEAT

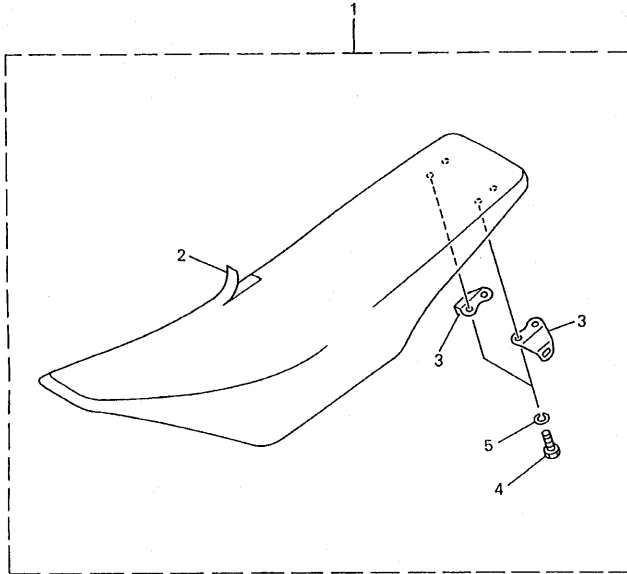

REF. NO.	PART NO.	DESCRIPTION					REMARKS
			5JG1	5JG2	5JG3	5JG4	
1	5GR-24710-10	SINGLE SEAT ASSY	1	1	1	1	
2	5GR-24731-10	.COVER, SEAT	1	1	1	1	
3	5BE-24728-00	.BRACKET, SEAT	2	2	2	2	
4	97007-06012	.BOLT	4	4	4	4	
5	92907-06100	.WASHER, SPRING	4	4	4	4	
-----							
-----							
-----							
-----							
-----							
-----							
-----							
-----							



5BE100-8270

FIG. 28 FRONT WHEEL

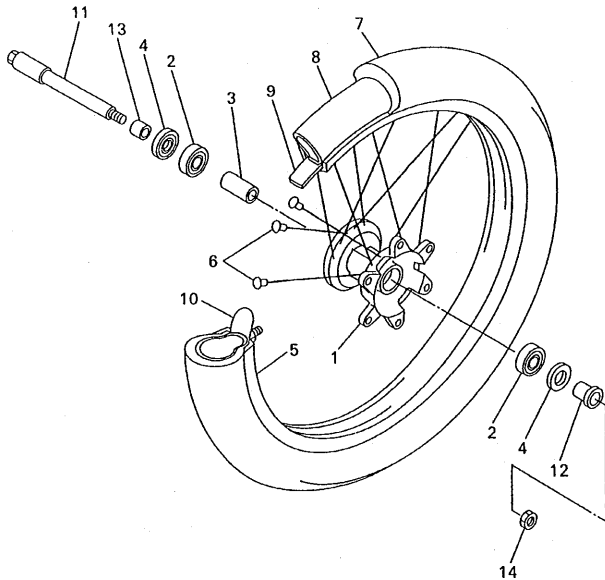

REF. NO.	PART NO.	DESCRIPTION	5JG1	5JG2	5JG3	5JG4	REMARKS
1	4SS-25111-00	HUB, FRONT	1	1	1	1	
2	93306-90403	BEARING	2	2	2	2	
3	5DH-25117-00	SPACER, BEARING	1	1	1	1	
4	93102-26468	OIL SEAL	2	2	2	2	
5	94416-21613	RIM (1.60-21)	1	1	1	1	
6	4DA-25104-00	SPOKE SET, FRONT	1	1	1	1	
7	94108-21008	TIRE (80/100-21 51M D739F)	1			1	DUNLOP
	94108-2112Y	TIRE (80/100-21 51M D755F)		1		1	DUNLOP FOR FRA, CAN
	*	TIRE (80/100-21 MT320)		1			LM PIRELLI
	94108-2110Y	TIRE (80/100-21 51M M77)			1		BRIDGESTONE
8	94227-21101	TUBE (80/100-21 TR4 BTL)	1	1		1	DUNLOP FOR FRA
	*	TUBE (80/100-21)		1			LM PIRELLI
	94209-21229	TUBE (80/100C-21 TR4)			1		BRIDGESTONE
9	94309-21161	BAND, RIM (70-80/100-21)	1	1		1	DUNLOP FOR FRA
	*	BAND, RIM (80/100-21)		1			LM PIRELLI
	94330-21084	BAND, RIM (3.00-21)			1		BRIDGESTONE
10	2J5-25394-01	SPACER, BEAD	1	1	1	1	
11	5BE-25181-00	AXLE, WHEEL	1	1	1	1	
12	5DH-25183-00	COLLAR, WHEEL	1	1	1	1	
13	5BE-25186-00	COLLAR, WHEEL	1	1	1	1	
14	90179-16672	NUT	1	1	1	1	



5BE100-8280

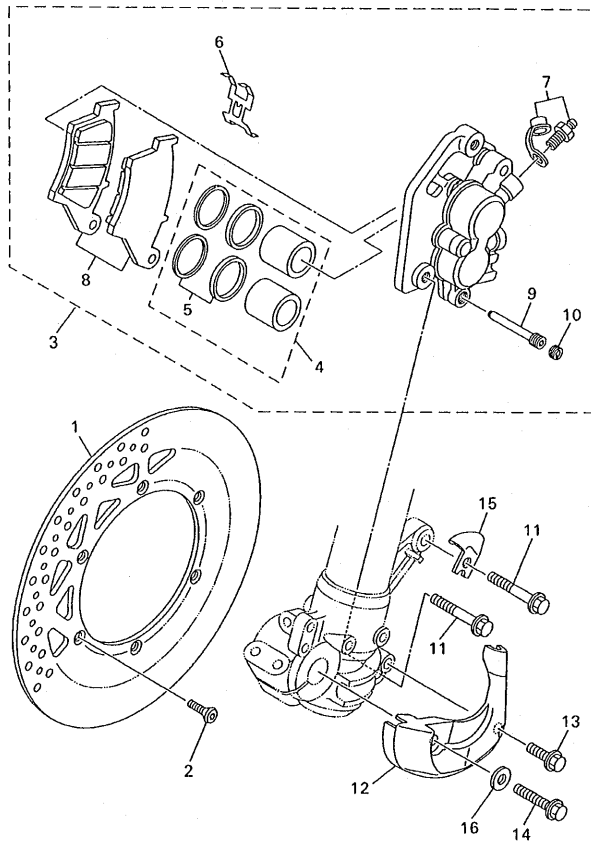
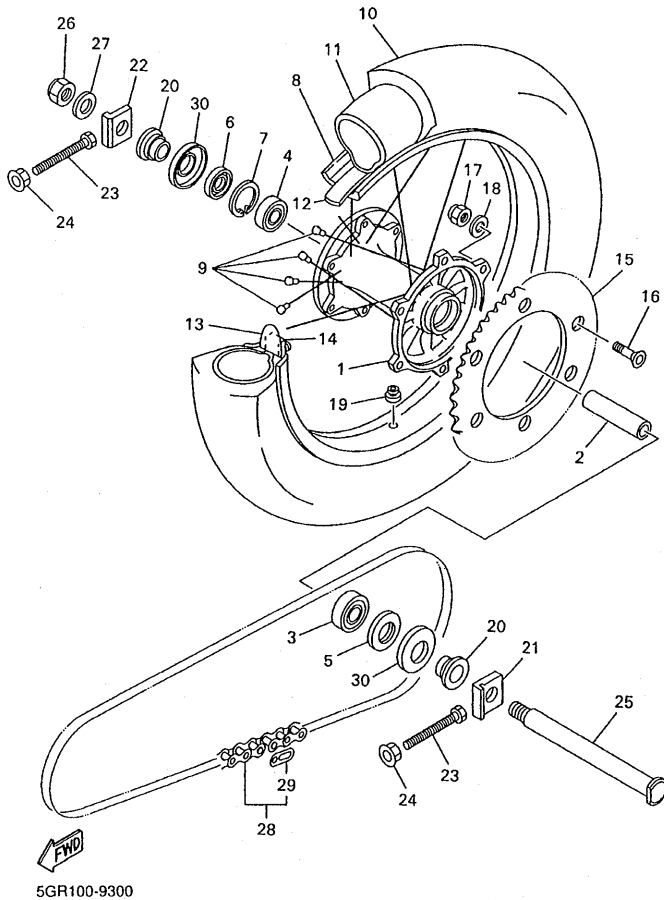

FIG. 29 FRONT BRAKE CALIPER

REF. NO.	PART NO.	DESCRIPTION	SUG1	SUG2	SUG3	SUG4	REMARKS
1	4XM-2582T-00	DISC, BRAKE	1	1	1	1	
2	90149-06327	SCREW	6	6	6	6	
3	5DH-2580T-00	CALIPER ASSY (LEFT)	1	1	1	1	
4	4EW-W0057-00	.PISTON ASSY, CALIPER	1	1	1	1	
5	3JD-W0047-00	..CALIPER SEAL KIT	1	1	1	1	
6	5DH-25919-00	.SUPPORT, PAD	1	1	1	1	
7	1UY-W0048-50	.BLEED SCREW KIT	1	1	1	1	
8	5DH-W0045-00	.BRAKE PAD KIT	1	1	1	1	
9	5DH-25933-00	.PIN, PAD	1	1	1	1	
10	5DH-25916-00	.PLUG	1	1	1	1	
11	90105-08659	BOLT, WASHER BASED	2	2	2	2	
12	5DH-2314E-00	COVER, HOSE	1	1	1	1	
13	95827-06012	BOLT, FLANGE	1	1	1	1	
14	95027-08020	BOLT, FLANGE	1	1	1	1	
15	5DH-25875-00	HOLDER, BRAKE HOSE 1	1	1	1	1	
16	92907-08200	WASHER	1	1	1	1	

FWD  
5BE100-8290

FIG. 30 REAR WHEEL



REF. NO.	PART NO.	DESCRIPTION					REMARKS
			5UG1	5UG2	5UG3	5UG4	
1	5ET-25311-00	HUB, REAR	1	1	1	1	
2	5ET-25317-00	SPACER, BEARING	1	1	1	1	
3	93306-27205	BEARING	1	1	1	1	
4	93306-07202	BEARING	1	1	1	1	
5	93106-30044	OIL SEAL	1	1	1	1	
6	93106-30045	OIL SEAL	1	1	1	1	
7	99009-45500	CIRCLIP	1	1	1	1	
8	94421-19602	RIM (2.15-19)	1	1	1	1	
9	5HD-25304-00	SPOKE SET, REAR	1	1	1	1	
10	94111-19008	TIRE (110/90-19 62M D739)	1			1	DUNLOP
	94111-1913A	TIRE (110/90-19 62M D755)		1		1	DUNLOP FOR FRA, CAN LM PIRELLI
	*	TIRE (110/90-19 MT320)		1			BRIDGESTONE
	94111-1911B	TIRE (110/90-19 62M M78A)			1		BRIDGESTONE
11	94211-19273	TUBE (110/90 110/100-19TR4)	1	1		1	DUNLOP FOR FRA
	*	TUBE (110/90-19)		1			LM PIRELLI
	94211-19274	TUBE (MCS 110/90-19 TR4)			1		BRIDGESTONE
12	94311-19155	BAND, RIM (110/90 110/100-19)	1	1		1	DUNLOP FOR FRA
	*	BAND, RIM (3.50-18 110/90-19)		1			LM METZELER
	94321-19157	BAND, RIM (2.15-19)			1		BRIDGESTONE
13	3JE-25394-00	SPACER, BEAD	1	1	1	1	
14	4XM-25364-00	DAMPER	1	1	1	1	
15	5ET-25449-00	SPROCKET, DRIVEN (49T)	1		1	1	STD
	5ET-25448-00	SPROCKET, DRIVEN (48T)		1			STD
	5ET-25447-00	SPROCKET, DRIVEN (47T)	1	1	1	1	AP
	5ET-25450-00	SPROCKET, DRIVEN (50T)	1	1	1	1	AP
	5ET-25451-00	SPROCKET, DRIVEN (51T)	1	1	1	1	AP
	5ET-25452-00	SPROCKET, DRIVEN (52T)	1	1	1	1	AP

FIG. 30 REAR WHEEL

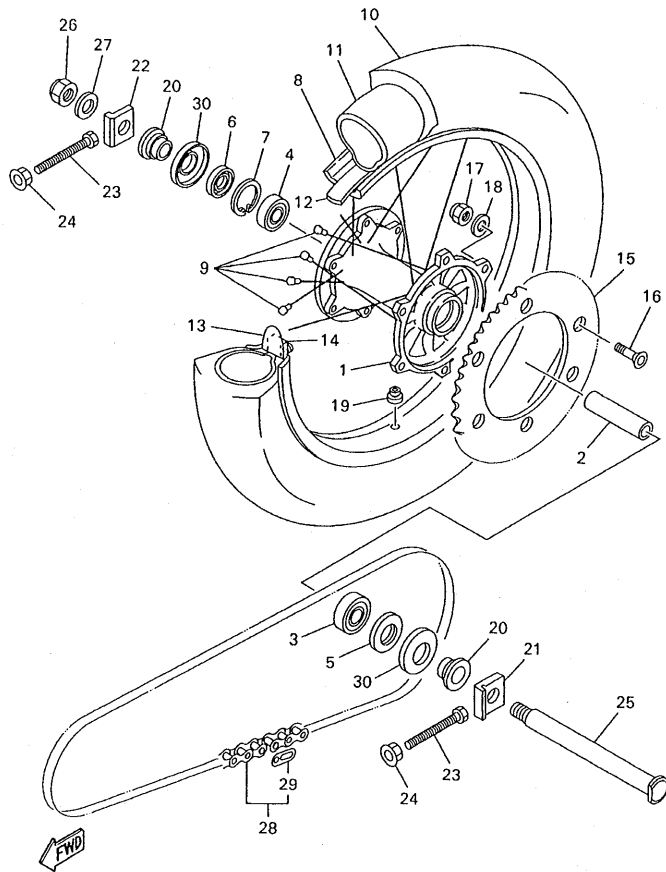

5GR100-9300

REF. NO.	PART NO.	DESCRIPTION					REMARKS
			5JG1	5JG2	5JG3	5JG4	
15	5ET-25448-00	SPROCKET, DRIVEN (48T)	1		1	1	AP
	5ET-25449-00	SPROCKET, DRIVEN (49T)		1			AP
16	90109-081G1	BOLT	6	6	6	6	
17	90185-08169	NUT, SELF-LOCKING	6	6	6	6	
18	90201-08326	WASHER, PLATE	6	6	6	6	
19	90480-08608	GROMMET	1	1	1	1	
20	5ET-25383-00	COLLAR, WHEEL	2	2	2	2	
21	5ET-25388-00	PULLER, CHAIN 1	1	1	1	1	
22	5ET-25389-00	PULLER, CHAIN 2	1	1	1	1	
23	90101-08777	BOLT	2	2	2	2	
24	90179-08299	NUT	2	2	2	2	
25	5ET-25381-00	AXLE, WHEEL	1	1	1	1	
26	90185-20168	NUT, SELF-LOCKING	1	1	1	1	
27	90201-203U1	WASHER, PLATE	1	1	1	1	
28	94581-68114	CHAIN (D.I.D.520DM 114LL)	1	1	1	1	
29	94681-68001	JOINT, CHAIN	1	1	1	1	
30	5ET-25367-00	COVER, HUB DUST	2	2	2	2	



FIG. 31 REAR BRAKE CALIPER

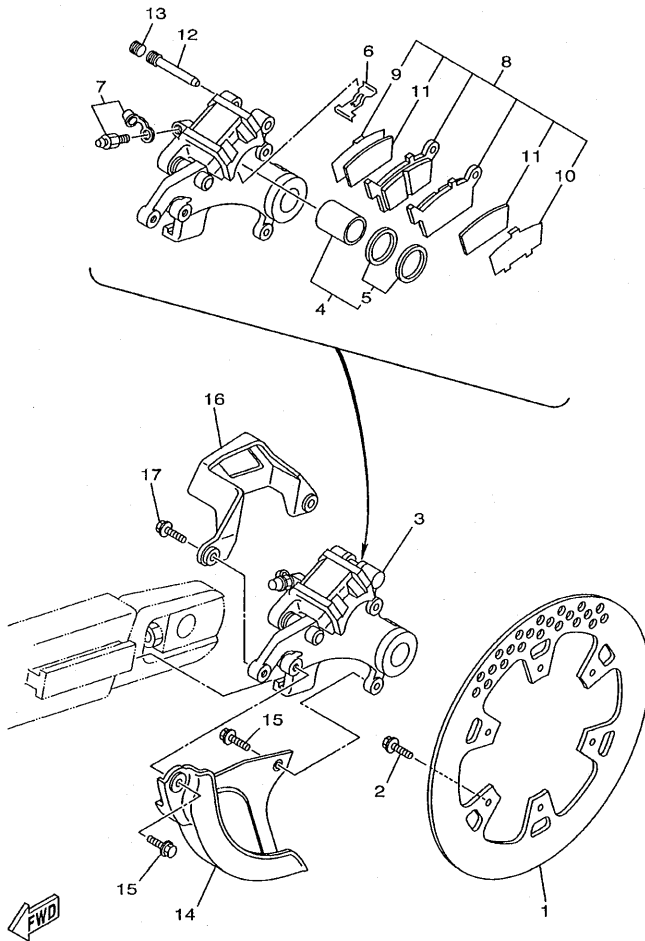

5ET1100-9280

REF. NO.	PART NO.	DESCRIPTION					REMARKS
			5/G1	5/G2	5/G3	5/G4	
1	5DH-2582W-00	DISC, REAR BRAKE 2	1	1	1	1	
2	90109-065G4	BOLT	6	6	6	6	
3	5GR-2580W-00	CALIPER ASSY, REAR 2	1	1	1	1	
4	5ET-W0057-50	.PISTON ASSY, CALIPER	1	1	1	1	
5	5ET-W0047-50	..CALIPER SEAL KIT	1	1	1	1	
6	5DH-25919-50	..SUPPORT, PAD	1	1	1	1	
7	1UY-W0048-50	..BLEED SCREW KIT	1	1	1	1	
8	5GR-W0046-00	..BRAKE PAD KIT 2	1	1	1	1	
9	5DH-25828-50	..SHIM, CALIPER	1	1	1	1	
10	5DH-25827-50	..SHIM, CALIPER	1	1	1	1	
11	5GR-22898-50	..INSULATOR, HEAT	2	2	2	2	
12	8CR-25924-00	..PIN, PAD	1	1	1	1	
13	5DH-25916-00	..PLUG	1	1	1	1	
14	5DH-25718-01	PROTECTOR, DISK BRAKE	1	1	1	1	
15	95027-06012	BOLT, FLANGE	2	2	2	2	
16	4GY-27491-00	PROTECTOR	1	1	1	1	
17	95027-06016	BOLT, FLANGE	2	2	2	2	

FIG. 32 STEERING HANDLE. CABLE

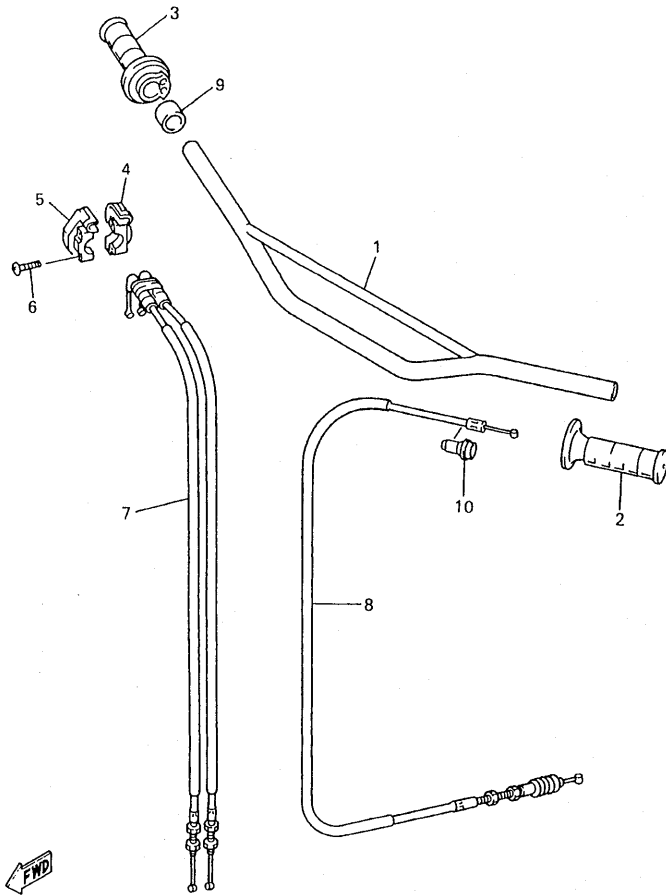

5JG1100-0320

REF. NO.	PART NO.	DESCRIPTION					REMARKS
			5JG1	5JG2	5JG3	5JG4	
1	4XM-26111-00	HANDLEBAR	1	1	1	1	
2	4GY-26241-00	GRIP (LEFT)	1	1	1	1	
3	5BE-26240-00	GRIP ASSY	1	1	1	1	
4	5BE-26281-00	CAP, GRIP UPPER	1	1	1	1	
5	5BE-26282-00	CAP, GRIP LOWER	1	1	1	1	
6	98507-05020	SCREW, PAN HEAD	2	2	2	2	
7	5JG-26302-00	THROTTLE CABLE ASSY	1	1	1	1	
8	5JG-26335-00	CABLE, CLUTCH	1	1	1	1	
9	90387-225N2	COLLAR	1	1	1	1	
10	5HD-26342-00	BOOT, CABLE	1	1	1	1	

FIG. 33 FRONT MASTER CYLINDER

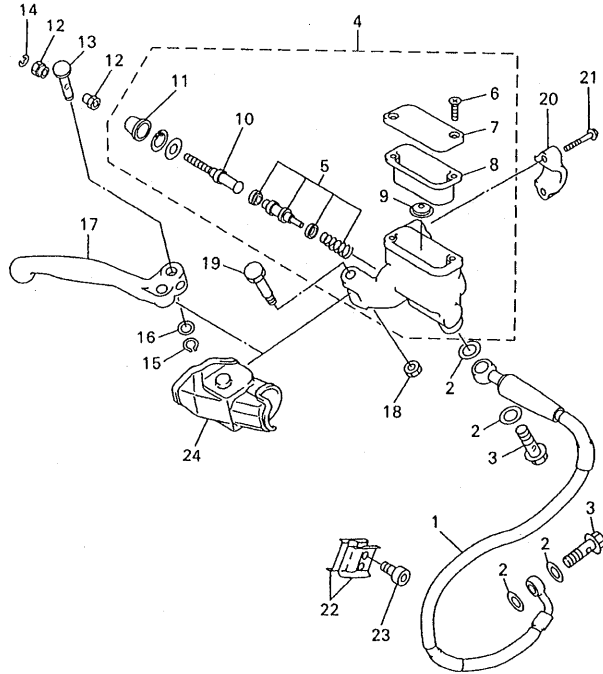

REF. NO.	PART NO.	DESCRIPTION					REMARKS
			5JG1	5UG2	5UG3	5UG5	
1	5ET-25872-00	HOSE, BRAKE 1	1	1	1	1	
2	90201-10118	WASHER, PLATE	4	4	4	4	
3	90401-10172	BOLT, UNION	2	2	2	2	
4	4SS-W2587-01	MASTER CYLINDER SUB ASSY	1	1	1	1	
5	4SS-W0041-00	.CYLINDER KIT, MASTER	1	1	1	1	
6	98706-04012	.SCREW, FLAT HEAD	2	2	2	2	
7	4SS-25852-00	.CAP, RESERVOIR	1	1	1	1	
8	4SS-25854-00	.DIAPHRAGM, RESERVOIR	1	1	1	1	
9	4SS-25889-00	.SEPARATOR ASSY	1	1	1	1	
10	4SS-25880-00	.PUSH ROD COMP.	1	1	1	1	
11	4SS-25868-00	.BOOT, MASTER CYLINDER	1	1	1	1	
12	4SS-2538E-00	NUT, ADJUSTING	2	2	2	2	
13	4SS-83913-00	COLLAR, LEVER 1	1	1	1	1	
14	3YX-25866-10	CIRCLIP	1	1	1	1	
15	4SS-25866-00	CIRCLIP	1	1	1	1	
16	4SS-2583G-00	WASHER	1	1	1	1	
17	4SS-83922-01	LEVER 2	1	1	1	1	
18	95806-06100	NUT, U	1	1	1	1	
19	4SS-2589F-00	BOLT, LEVER	1	1	1	1	
20	3YK-25867-00	BRACKET, MASTER CYLINDER	1	1	1	1	
21	4SS-25833-00	BOLT, FITTING	2	2	2	2	
22	90465-16258	CLAMP	2	2	2	2	
23	91317-06014	BOLT	2	2	2	2	
24	5JG-26372-00	COVER, HANDLE LEVER 1	1	1	1	1	



5JG1100-0330

FIG. 34 STAND, FOOTREST

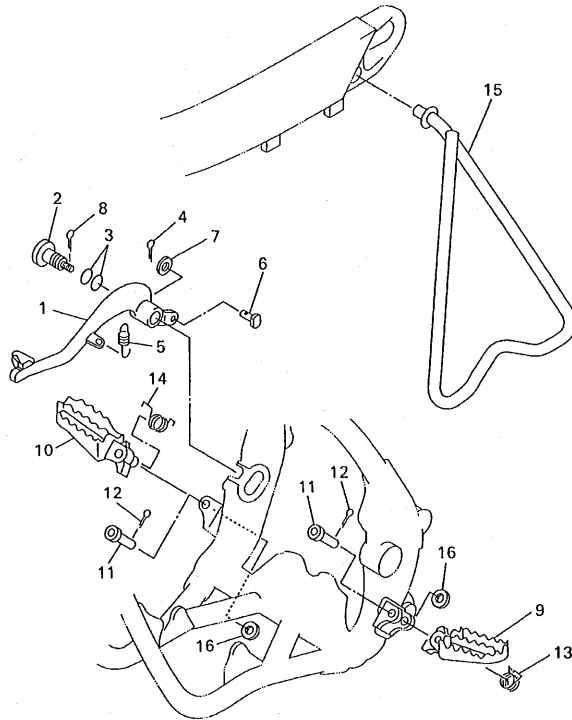

REF. NO.	PART NO.	DESCRIPTION	SJG1	SJG2	SJG3	SJG4	REMARKS
1	4XM-27200-00	PEDAL, BRAKE	1	1	1	1	
2	5JG-27217-00	BOLT	1	1	1	1	
3	93210-11073	O-RING	2	2	2	2	
4	91401-20012	PIN, COTTER	1	1	1	1	
5	90506-16500	SPRING, TENSION	1	1	1	1	
6	90240-08120	PIN, CLEVIS	1	1	1	1	
7	90201-08089	WASHER, PLATE	1	1	1	1	
8	90468-16191	CLIP	1	1	1	1	
9	5ET-27411-00	FOOTREST 1	1	1	1	1	
10	5ET-27421-00	FOOTREST 2	1	1	1	1	
11	90240-10142	PIN, CLEVIS	2	2	2	2	
12	91401-25015	PIN, COTTER	2	2	2	2	
13	90508-282B8	SPRING, TORSION	1	1	1	1	
14	90508-282B9	SPRING, TORSION	1	1	1	1	
15	5ET-27311-00	STAND, SIDE	1	1	1	1	
16	90201-10119	WASHER, PLATE	2	2	2	2	



5BE100-8340

FIG. 35 REAR MASTER CYLINDER

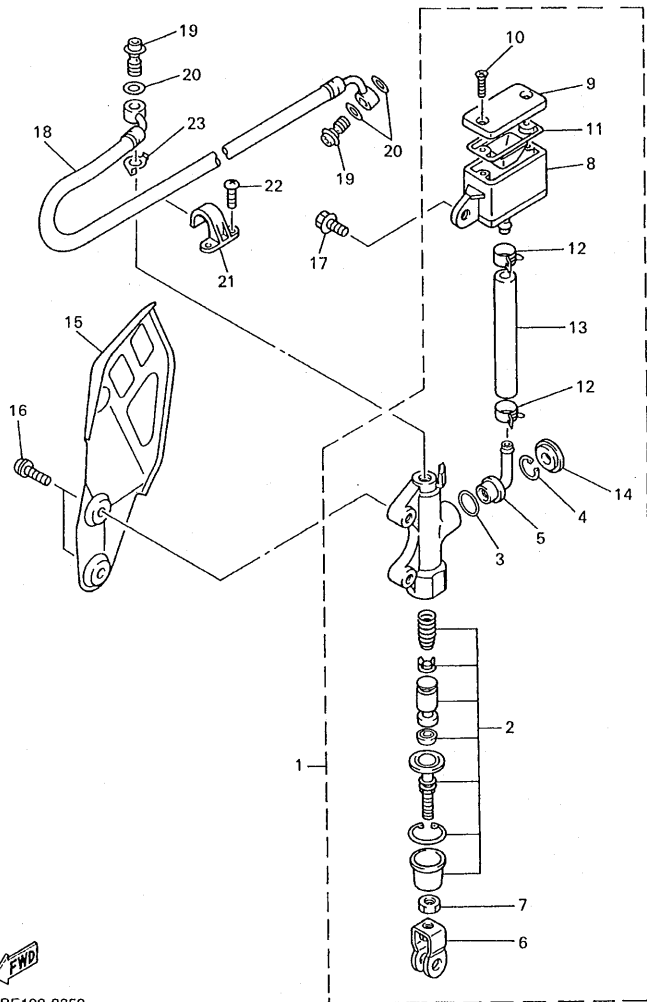

REF. NO.	PART NO.	DESCRIPTION					REMARKS
			5UG1	5UG2	5UG3	5UG4	
1	5JG-2583V-00	RR. MASTER CYLINDER ASSY.	1	1	1	1	
2	4SS-W0042-50	.CYLINDER KIT, MASTER	1	1	1	1	
3	93210-15620	.O-RING	1	1	1	1	
4	2VN-25866-00	.CIRCLIP	1	1	1	1	
5	4ML-2582A-50	.JOINT	1	1	1	1	
6	3SP-27222-00	.JOINT	1	1	1	1	
7	95301-08700	.NUT	2	2	2	2	
8	5BE-25894-00	.TANK, RESERVOIR	1	1	1	1	
9	5BE-25852-00	.CAP, RESERVOIR	1	1	1	1	
10	98706-04040	.SCREW, FLAT HEAD	2	2	2	2	
11	56A-25854-00	.DIAPHRAGM, RESERVOIR	1	1	1	1	
12	90467-12085	.CLIP	2	2	2	2	
13	5BE-25895-00	.HOSE, RESERVOIR	1	1	1	1	
14	3FV-2589A-00	.COVER, DUST	1	1	1	1	
15	5BE-2117M-00	COVER 2	1	1	1	1	
16	92014-06016	BOLT, BUTTON HEAD	2	2	2	2	
17	95027-06012	BOLT, FLANGE	1	1	1	1	
18	5DH-25873-00	HOSE, BRAKE 2	1	1	1	1	
19	90401-10172	BOLT, UNION	2	2	2	2	
20	90201-10118	WASHER, PLATE	3	3	3	3	
21	2VM-25876-00	HOLDER, BRAKE HOSE 2	2	2	2	2	
22	97780-50510	SCREW, TAPPING	4	4	4	4	
23	5BE-25844-00	WASHER, LOCK	1	1	1	1	



5BE100-8350



FIG. 37 HANDLE SWITCH. LEVER

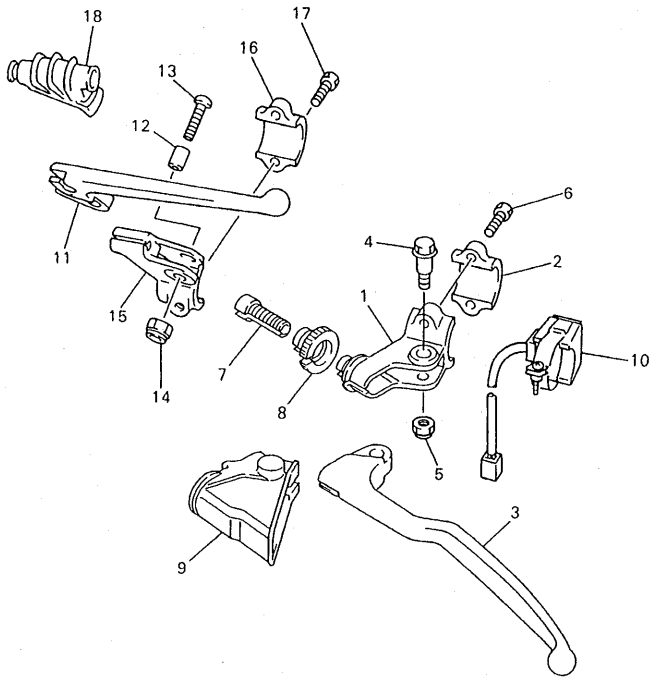

REF. NO.	PART NO.	DESCRIPTION					REMARKS
			5JG1	5JG2	5JG3	5JG4	
1	5HD-82911-00	HOLDER, LEVER 1	1	1	1	1	
2	38V-82913-00	HOLDER, LEVER LOWER 1	1	1	1	1	
3	5HD-83912-00	LEVER 1	1	1	1	1	
4	90109-06027	BOLT	1	1	1	1	
5	95607-06100	NUT, U	1	1	1	1	
6	97007-05016	BOLT	2	2	2	2	
7	5HD-26337-00	BOLT, ADJUSTING	1	1	1	1	
8	5HD-83951-00	BOLT, CABLE ADJUSTING	1	1	1	1	
9	5HD-26372-00	COVER, HANDLE LEVER 1	1	1	1	1	
10	23X-83976-00	SWITCH, HANDLE 1	1	1	1	1	
11	583-83981-00	LEVER, DECOMPRESSION	1	1	1	1	
12	5BE-83913-00	COLLAR, LEVER 1	1	1	1	1	
13	98907-05020	SCREW, BIND	1	1	1	1	
14	95607-05100	NUT, U	1	1	1	1	
15	5BE-82912-00	HOLDER, LEVER UPPER 1	1	1	1	1	
16	38V-82913-00	HOLDER, LEVER LOWER 1	1	1	1	1	
17	97007-05016	BOLT	2	2	2	2	
18	583-26352-00	COVER, DECOMPRESSION CABLE	1	1	1	1	



5JG1100-0370

FIG. 38 ELECTRICAL 1

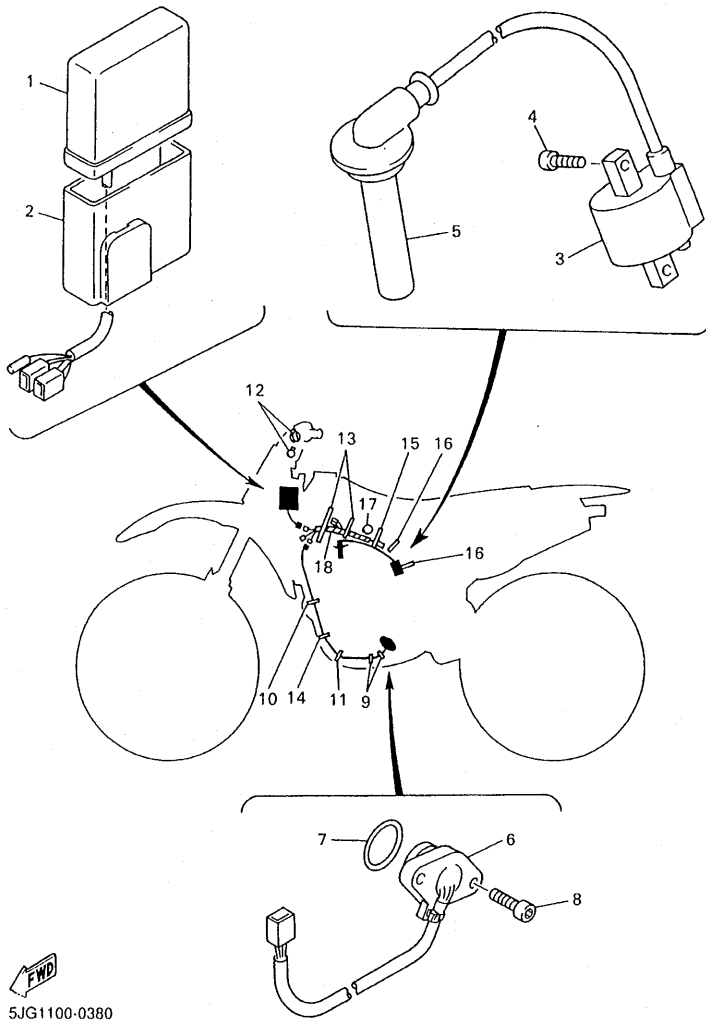

REF. NO.	PART NO.	DESCRIPTION					REMARKS
			5JG1	5JG2	5JG3	5JG4	
1	5JG-85540-00	C.D.I. UNIT ASSY	1	1	1	1	
2	5BE-85546-00	BAND	1	1	1	1	
3	5BE-82310-00	IGNITION COIL ASSY	1	1	1	1	
4	91317-06016	BOLT	2	2	2	2	
5	5BE-82370-00	PLUG CAP ASSY	1	1	1	1	
6	5BE-82540-01	NEUTRAL SWITCH ASSY	1	1	1	1	
7	93210-21276	O-RING	1	1	1	1	
8	90154-05073	SCREW, BINDING	2	2	2	2	
9	90464-16061	CLAMP	2	2	2	2	
10	90464-13073	CLAMP	1	1	1	1	
11	90460-15126	CLAMP, HOSE	1	1	1	1	
12	90464-13077	CLAMP	2	2	2	2	
13	90464-15152	CLAMP	2	2	2	2	
14	90464-13073	CLAMP	1	1	1	1	
15	90465-13275	CLAMP	1	1	1	1	
16	90464-15195	CLAMP	2	2	2	2	
17	90465-13152	CLAMP	1	1	1	1	
18	5JG-82509-00	WIRE, SUB LEAD	1	1	1	1	

FWD  
5JG1100-0380



FIG. 39 ALTERNATE (CHASSIS)

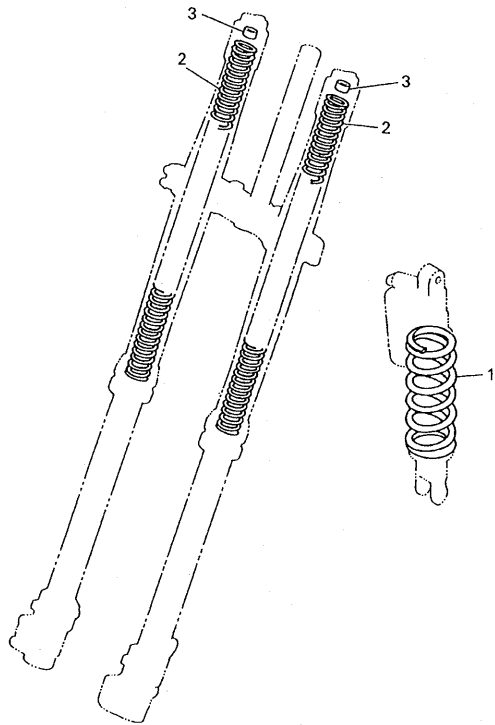

REF. NO.	PART NO.	DESCRIPTION	SJG1	SJG2	SJG3	SJG4	REMARKS
1	5DH-22212-70	SPRING (K=4.4)	1	1	1	1	AP
	5DH-22212-10	SPRING (K=4.6)	1	1	1	1	AP
	5DH-22212-20	SPRING (K=4.8)	1	1	1	1	AP
	5DH-22212-30	SPRING (K=5.0)	1	1	1	1	AP
	5DH-22212-40	SPRING (K=5.2)	1	1	1	1	AP
	5DH-22212-50	SPRING (K=5.4)	1	1	1	1	AP
	5DH-22212-60	SPRING (K=5.6)	1	1	1	1	AP
	5ET-22212-20	SPRING (K=APPROX.4.6)	1	1	1	1	AP
	5ET-22212-00	SPRING (K=APPROX.4.8)	1	1	1	1	AP
	5ET-22212-10	SPRING (K=APPROX.5.0)	1	1	1	1	AP
	5ET-22212-30	SPRING (K=APPROX.5.2)	1	1	1	1	AP
	5ET-22212-40	SPRING (K=APPROX.5.4)	1	1	1	1	AP
	5ET-22212-50	SPRING (K=APPROX.5.6)	1	1	1	1	AP
2	4SS-23141-10	SPRING, FRONT FORK (K=0.38)	2	2	2	2	AP
	4SS-23141-20	SPRING, FRONT FORK (K=0.39)	2	2	2	2	AP
	4SS-23141-30	SPRING, FRONT FORK (K=0.40)	2	2	2	2	AP
	4SS-23141-40	SPRING, FRONT FORK (K=0.41)	2	2	2	2	AP
	4SS-23141-50	SPRING, FRONT FORK (K=0.42)	2	2	2	2	AP
	4SS-23141-60	SPRING, FRONT FORK (K=0.43)	2	2	2	2	AP
	4SS-23141-70	SPRING, FRONT FORK (K=0.44)	2	2	2	2	AP
	5BE-23141-L0	SPRING, FRONT FORK (K=0.45)	2	2	2	2	AP
	5BE-23141-00	SPRING, FRONT FORK (K=0.46)	2	2	2	2	AP
	5GR-23141-00	SPRING, FRONT FORK (K=0.47)	2	2	2	2	AP
	5ET-23141-20	SPRING (K=APPROX.0.40)	2	2	2	2	AP
	5ET-23141-00	SPRING (K=APPROX.0.41)	2	2	2	2	AP
	5ET-23141-30	SPRING (K=APPROX.0.42)	2	2	2	2	AP
	5ET-23141-10	SPRING (K=APPROX.0.43)	2	2	2	2	AP



5BE100-8390

FIG. 39 ALTERNATE (CHASSIS)

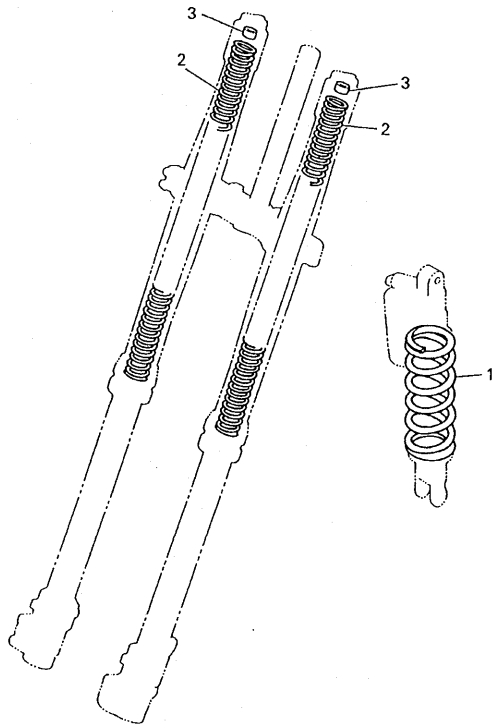

REF. NO.	PART NO.	DESCRIPTION					REMARKS
			5JG1	5JG2	5JG3	5JG4	
2	5ET-23141-40	SPRING (K=APPROX.0.44)	2	2	2	2	AP
3	4SS-23364-L0	COLLAR 2	2	2	2	2	UN

 5BE100-8390

NUMERICAL INDEX

PARTNO.	GRID NO.	PARTNO.	GRID NO.	PARTNO.	GRID NO.	PARTNO.	GRID NO.	PARTNO.	GRID NO.	PARTNO.	GRID NO.
4SS-W0041-00	E - 5	3FV-12153-00	B - 6	5BE-12576-00	B - 9	5BE-1443E-00	B - 13	5JG-14916-FR	B - 15	5BE-15150-02	C - 5
4SS-W0042-50	E - 7	3FV-12153-10	B - 6	5BE-12577-00	B - 9	5BE-14449-00	C - 3	5JG-14916-FS	B - 15	5BE-15362-00	C - 14
5DH-W0045-00	D - 14	3FV-12153-20	B - 6	5BE-12578-00	B - 9	4XM-14451-00	B - 13	5JG-14916-FT	B - 15	4JT-15381-01	C - 5
5GR-W0046-00	E - 3	3LD-12168-A0	B - 5	5BE-12579-01	B - 9	5JG-14453-00	B - 13	5JG-14916-FU	B - 15	5BE-15383-00	C - 5
3JD-W0047-00	D - 14	3LD-12168-F0	B - 5	583-13113-00	C - 6	5BE-14458-00	B - 13	5JG-14916-F1	B - 15	5BE-15411-00	C - 6
5ET-W0047-50	E - 3	3LD-12168-H1	B - 5	5BE-13161-01	B - 12	3JD-14459-01	B - 13	5JG-14922-00	C - 3	5JG-15415-00	C - 6
1UY-W0048-50	D - 14	3LD-12168-K1	B - 5	5BE-13171-00	B - 12	3JD-14477-00	B - 13	3TJ-14933-40	C - 3	5BE-15421-00	C - 5
	E - 3	3LD-12168-M1	B - 5	5BE-13300-00	B - 10	5JG-14521-00	B - 15	4FN-14934-00	C - 3	5JG-15431-00	C - 5
4EW-W0057-00	D - 14	3LD-12168-R1	B - 5	1HX-13310-00	B - 10	5JG-14522-00	B - 14	3TJ-1494F-12	C - 2	5BE-15441-00	C - 6
5ET-W0057-50	E - 3	3LD-12168-U1	B - 5	5BE-13341-00	B - 10	5JG-14531-00	C - 3	3TJ-1494F-13	C - 2	5BE-15451-00	C - 6
4SS-W2587-01	E - 5	3LD-12168-W1	B - 5	5BE-13342-00	B - 10	3TJ-14536-40	C - 3	3TJ-1494F-14	C - 2	5JG-15453-00	C - 6
5JG-11102-00	B - 2	3LD-12168-Y1	B - 5	5BE-13411-00	B - 10	5JG-14546-00	B - 14	3TJ-1494F-15	C - 2	5BE-15462-00	C - 6
4KG-1111G-00	B - 2	3LD-12168-00	B - 5	5BE-13412-00	B - 10	676-14548-00	C - 2	3TJ-1494F-16	C - 2	5GR-15601-00	C - 7
5BE-11133-10	B - 2	3LD-12168-20	B - 5	5BE-13416-00	B - 10	4YR-14557-00	C - 3	3TJ-1494F-17	C - 2	5BE-15620-02	C - 7
5BE-11134-10	B - 2	3LD-12168-40	B - 5	1UY-13440-02	B - 12	4FN-14561-00	B - 13	3TJ-1494F-18	C - 2	3SP-15621-02	C - 7
5BE-11166-00	B - 3	3LD-12168-60	B - 5	5BE-13447-00	B - 12	4MX-14561-00	C - 3	3TJ-1494F-19	C - 2	5BE-15651-00	C - 7
371-11167-01	B - 3	3LD-12168-80	B - 5	5BE-13464-00	B - 10	6H4-14561-00	C - 3	3TJ-1494F-20	C - 2	5GR-15664-00	C - 7
5BE-11167-00	B - 2	3LD-12169-E0	B - 6	5BE-13465-00	B - 10	5BE-14562-00	C - 3	5BE-14940-15	C - 2	5BE-15668-00	C - 7
5JG-11181-00	B - 2	3LD-12169-G0	B - 6	5JG-13597-00	B - 13	5JG-14565-00	C - 3	5BE-14940-17	C - 2	5BE-15674-00	C - 7
5BE-11191-00	B - 2	3LD-12169-J0	B - 6	5JG-14101-00	B - 14	5JG-14591-00	C - 3	5BE-14940-18	C - 2	5BE-15686-01	C - 7
5BE-11193-10	B - 3	3LD-12169-L0	B - 6	5JG-14101-10	B - 14	5BE-14611-00	C - 4	5BE-14940-19	C - 2	5JG-16111-00	C - 8
5JG-11311-00	B - 3	3LD-12169-N0	B - 6	3TJ-14105-40	C - 2	3VD-14613-00	C - 4	3TJ-14943-47	B - 15	5JG-16150-00	C - 8
5BE-11351-00	B - 3	3LD-12169-T0	B - 6	5BE-14107-00	C - 2	5BE-14628-00	C - 4	4MX-14943-38	B - 15	2JN-16154-00	C - 8
5JG-11387-00	B - 3	3LD-12169-11	B - 5	4MX-14115-00	C - 3	5BE-1469A-10	C - 4	4MX-14943-39	B - 15	3XK-16321-00	C - 8
5JG-11400-00	B - 4	3LD-12169-31	B - 6	3TJ-14137-40	C - 3	5JG-1469A-00	C - 4	4MX-14943-40	B - 15	5JG-16325-00	C - 8
5JG-11412-00	B - 4	3LD-12169-50	B - 6	5BE-14146-00	C - 3	5BE-1469E-00	C - 4	4MX-14943-41	B - 15	5JG-16351-00	C - 8
5JG-11422-00	B - 4	3LD-12169-70	B - 6	5JG-14146-00	C - 3	3GW-14714-00	C - 4	4MX-14943-42	B - 15	5BE-16356-00	C - 8
5BE-11454-00	B - 4	3LD-12169-90	B - 6	3TJ-14159-40	B - 15	5BE-14747-00	C - 4	4MX-14943-88	B - 15	5JG-16357-00	C - 8
5BE-11455-00	B - 4	5BE-12170-00	B - 7	5JG-14171-00	C - 3	5JG-14753-00	C - 4	4MX-14943-89	B - 15	5JG-16371-00	C - 8
5BE-11531-00	B - 4	5BE-12180-00	B - 7	5JG-14197-00	C - 3	5JG-14753-10	C - 4	4MX-14943-90	B - 15	5BE-16381-00	C - 8
5BE-11536-00	B - 4	5BE-12210-00	B - 7	5JG-14197-10	C - 3	4BD-14766-00	C - 4	4MX-14943-91	B - 15	4JT-16384-00	C - 8
5JG-11603-00	B - 4	4FM-12213-00	B - 7	5BE-14216-00	C - 2	5BE-14788-00	C - 4	4MX-14943-92	B - 15	5JG-17121-00	C - 9
5JG-11631-00	B - 4	5BE-12241-00	B - 7	5JG-14264-00	B - 15	5JG-14916-DN	B - 14	4MX-14943-93	B - 15	5BE-17131-10	C - 9
5JG-11633-00	B - 4	5BE-12251-10	B - 7	3TJ-14267-40	B - 14	5JG-14916-DP	B - 14	7A9-14943-27	C - 2	5BE-17141-20	C - 9
5JG-11651-00	B - 4	5BE-12252-00	B - 7	5JG-14275-00	B - 15	5JG-14916-DR	B - 14	5JG-14947-00	B - 15	5BE-17151-00	C - 9
5BE-11681-00	B - 4	5BE-12280-10	B - 7	3TJ-14293-40	C - 2	5JG-14916-DS	B - 14	4MX-14948-01	C - 2	5JG-17211-00	C - 9
5BE-12111-10	B - 5	5BE-12283-00	B - 7	5JG-14293-00	B - 13	5JG-14916-DT	B - 14	4MX-14948-02	C - 2	5JG-17221-00	C - 9
5BE-12112-10	B - 5	5BE-12292-00	B - 7	3TJ-14325-40	C - 3	5JG-14916-DU	B - 14	4MX-14948-03	C - 2	5BE-17231-00	C - 9
5BE-12113-00	B - 5	5JG-1240A-00	B - 9	5JG-14346-00	C - 3	5JG-14916-D1	B - 14	4MX-14948-04	B - 15	5BE-17241-10	C - 9
5GR-12114-00	B - 5	5BE-12422-10	B - 8	5JG-14371-00	C - 3	5JG-14916-EN	B - 14	4MX-14948-05	C - 2	5BE-17251-10	C - 9
4GY-12117-00	B - 5	5BE-12439-00	B - 8	5JG-14379-00	C - 3	5JG-14916-EP	B - 14	4MX-14948-06	C - 2	5JG-17411-00	C - 9
5BE-12117-00	B - 5	5DJ-12451-00	B - 8	5JG-14388-00	B - 14	5JG-14916-ER	B - 14	4MX-14948-07	C - 2	5BE-17421-00	C - 9
1AA-12118-00	B - 5	5GR-12458-00	B - 8	5JG-1440F-00	B - 13	5JG-14916-ES	B - 14	5JG-14951-00	B - 14	5BE-17466-10	C - 5
1WG-12118-00	B - 5	5JG-12461-00	B - 9	5JG-14401-00	B - 13	5JG-14916-ET	B - 15	5JG-14959-00	B - 14	4LO-17471-00	C - 5
33M-12119-00	B - 5	5HD-12462-00	B - 9	5BE-1441A-00	B - 13	5JG-14916-EU	B - 15	5JG-14984-00	C - 2	5GR-17471-00	C - 10
4SV-12119-00	B - 5	5BE-12481-10	B - 9	5BE-1441E-00	B - 13	5JG-14916-E1	B - 14	4SR-14985-00	C - 2	3XK-18101-02	C - 12
5BE-12121-10	B - 5	5BE-12482-00	B - 9	5JG-14417-00	B - 13	5JG-14916-FN	B - 15	5JG-14987-00	C - 3	5BE-18110-00	C - 12
3GM-12126-00	B - 5	5BE-12564-00	B - 8	5JG-14428-00	B - 13	5JG-14916-FP	B - 15	4FN-14997-00	B - 14	3XK-18122-00	C - 12



NUMERICAL INDEX

PARTNO.	GRID NO.	PARTNO.	GRID NO.	PARTNO.	GRID NO.	PARTNO.	GRID NO.	PARTNO.	GRID NO.	PARTNO.	GRID NO.
3XK-18140-00	C-11	5JG-22201-10	D-5	5ET-23125-LO	D-8	5JG-23170-MO	D-9	5ET-25367-00	E-2	5DH-25916-00	E-3
5BE-18172-00	C-12	5JG-22201-20	D-5			5ET-23171-LO	D-8	4SS-2538E-00	E-5	5DH-25919-00	D-14
3XJ-18173-00	C-12	5JG-22201-30	D-5	5HD-23136-LO	D-8			5ET-25381-00	E-2	5DH-25919-50	E-3
3XJ-18178-00	C-12	5JG-22201-40	D-5	5DH-2314E-00	D-14	5DH-23183-00	D-5	5ET-25383-00	E-2	8CR-25924-00	E-3
3XJ-18182-00	C-12	5JG-22210-00	D-5	5DH-2314F-LO	D-9	509-23184-LO	D-5	5ET-25388-00	E-2	5DH-25933-00	D-14
3XJ-18184-00	C-12	5JG-22210-10	D-5	4SS-2314G-LO	D-9	5DH-23195-LO	D-8	5ET-25389-00	E-2	4XM-26111-00	E-4
4EW-18185-00	C-12	5JG-22210-20	D-5	5DH-2314H-00	D-10			2J5-25394-01	D-13	5BE-26240-00	E-4
5BE-18501-00	C-11	5JG-22210-30	D-5	5DH-2314J-00	D-9	5HC-2331E-00	D-10	3JE-25394-00	D-15	4GY-26241-00	E-4
5BE-18502-10	C-11	5JG-22210-40	D-5	4SS-23141-10	E-11	5HC-23340-LO	D-9	5ET-25447-00	D-15	5BE-26281-00	E-4
5BE-18503-00	C-11	5DH-22212-10	E-11	4SS-23141-20	E-11	4SS-23346-LO	D-9	5ET-25448-00	D-15	5BE-26282-00	E-4
5BE-18541-00	C-11	5DH-22212-20	E-11	4SS-23141-30	E-11	3SP-23356-LO	D-10			5JG-26302-00	E-4
4BA-18542-00	C-11	5DH-22212-30	E-11	4SS-23141-40	E-11	4SS-23364-LO	E-12	5ET-25449-00	D-15	5JG-26335-00	E-4
5DH-18562-00	C-5	5DH-22212-40	E-11	4SS-23141-50	E-11	4DA-23389-00	D-7			5HD-26337-00	E-9
5JG-21110-00-PO	C-13	5DH-22212-50	D-5	4SS-23141-60	E-11	5HD-2339E-00	D-7	5ET-25450-00	D-15	5HD-26342-00	E-4
5BE-2117M-00	E-7			4SS-23141-70	E-11	5HD-23393-LO	D-8	5ET-25451-00	D-15	583-26352-00	E-9
5JG-21190-00-PO	C-13	5DH-22212-60	E-11	5BE-23141-LO	D-8			5ET-25452-00	D-15	5HD-26372-00	E-9
5HD-2135F-00	D-4	5DH-22212-70	E-11			4EW-23416-00	D-7	5DH-25718-01	E-3	5JG-26372-00	E-5
5BE-21417-00	C-14	5ET-22212-00	E-11	5BE-23141-00	E-11	5HC-23435-10	D-7	5DH-2580T-00	D-14	4XM-27200-00	E-6
5BE-21425-01	C-13	5ET-22212-10	E-11	5ET-23141-00	E-11	3SP-23441-00	D-7	5GR-2580W-00	E-3	5JG-27217-00	E-6
5GR-21425-01	C-13	5ET-22212-20	E-11	5ET-23141-10	E-11	5HD-23485-00	D-7	4ML-2582A-50	E-7	3SP-27222-00	E-7
5BE-2147A-00	C-14	5ET-22212-30	E-11	5ET-23141-20	E-11	5GR-24110-10	D-11	4XM-2582T-00	D-14	5ET-27311-00	E-6
5BE-21471-00	C-14	5ET-22212-40	E-11	5ET-23141-30	E-11	4EW-2412F-00	D-11	5DH-2582W-00	E-3	5ET-27411-00	E-6
5HD-21511-00	C-15			5ET-23141-40	E-11	24X-24144-00	D-11	5DH-25827-50	E-3	5ET-27421-00	E-6
3FY-21575-01	D-2	5ET-22212-50	E-11	5ET-23141-50	E-12	3SP-24173-00	D-11	5DH-25828-50	E-3	4GY-27491-00	E-3
5BE-21611-10	C-15	3SP-22213-00	D-5	5GR-23141-LO	D-8	22W-24181-00	C-4	4SS-2583G-00	E-5	5BE-2814F-00	C-14
5JG-2163G-00	C-15	5DH-22214-00	D-5	5GR-23141-00	E-11	4SS-24181-00	D-11	5JG-2583V-00	E-7	5ET-28166-00	C-14
5BE-21642-00	C-15	5DH-22224-00	D-5	5DH-23142-LO	D-8	5BE-24182-00	D-11	4SS-25833-00	E-7	5BE-82310-00	E-10
5BE-21711-00	D-2	4JX-22226-00	D-5			3JD-24186-00	D-11	5BE-25844-00	E-7	5BE-82370-00	E-10
5JG-2172A-00	D-2	3SP-22234-00	D-5	5HD-23144-LO	D-8	5JG-24240-00	D-11	4SS-25852-00	E-5	5JG-82509-00	E-10
5BE-21721-00	D-2	4EW-22253-00	D-5			3XJ-24380-00	D-11	5BE-25852-00	E-7	5BE-82540-01	E-10
5JG-2173E-00	D-2	5DH-22253-00	D-5	5ET-23145-LO	D-8	4DP-24500-00	D-11	4SS-25854-00	E-5	5HD-82911-00	E-9
5JG-2173F-00	D-2	5ET-22355-00	D-3			4X8-24512-00	D-11	56A-25854-00	E-7	5BE-82912-00	E-9
5JG-21731-00	D-2	3V6-22358-00	D-11	4SS-23146-LO	D-8	3AJ-24523-00	D-11	2VN-25866-00	E-7	38V-82913-00	E-9
5BE-2174A-00	D-2	4EW-22474-00	D-5			3AJ-24534-00	D-11	3YX-25866-10	E-5	5HD-83912-00	E-9
5JG-21741-00	D-2	3JE-22475-00	D-5	5DH-23149-LO	D-8	1UY-24610-00	D-11	4SS-25866-00	E-5	4SS-83913-00	E-5
3JD-21748-00	C-15	5GR-22898-50	E-3			5GR-24710-10	D-12	3YK-25867-00	E-5	5BE-83913-00	E-9
5BE-21756-00	C-13	5JG-23102-LO	D-8	4SS-23153-LO	D-8	5BE-24728-00	D-12	4SS-25868-00	E-5	4SS-83922-01	E-5
5CU-22110-00	D-3	5JG-23102-MO	D-8			5GR-24731-10	D-12	5ET-25872-00	E-5	5HD-83951-00	E-9
4XM-22128-00	D-3	5JG-23103-LO	D-8	4SS-23158-LO	D-8	4DA-25104-00	D-13	5DH-25873-00	E-7	23X-83976-00	E-9
5DH-22141-00	D-3	5JG-23103-MO	D-8			4SS-25111-00	D-13	5DH-25875-00	D-14	583-83981-00	E-9
5JG-22151-00	D-3	5BF-23110-LO	D-9	5JG-2316A-LO	D-8	5DH-25117-00	D-13	2VM-25876-00	E-7	5JG-85540-00	E-10
5JG-22156-00	D-3	5HD-23111-LO	D-8			5BE-25181-00	D-13	4SS-25880-00	E-5	5BE-85546-00	E-10
5ET-2217A-00	D-3			5JG-2316A-MO	D-8	5DH-25183-00	D-13	4SS-25889-00	E-5	5JG-85550-00	E-8
5DH-2217F-01	D-4	5DH-23118-LO	D-8			5BE-25186-00	D-13	3FV-2589A-00	E-7	5BE-85560-02	E-8
3JD-22178-01	C-13			5JG-23170-LO	D-8	5HD-25304-00	D-15	4SS-2589F-00	E-5	5JG-85885-00	C-3
4EW-22178-00	C-13	3JD-2312G-LO	D-8			5ET-25311-00	D-15	5BE-25894-00	E-7	90101-06001	C-7
4XM-22199-00	D-3			5JG-23170-MO	D-8	5ET-25317-00	D-15	5BE-25895-00	E-7	90101-06664	C-12
5JG-22201-00	D-5	5DH-23120-LO	D-8			4XM-25364-00	D-15	5DH-25916-00	D-14	90101-08777	E-2

NUMERICAL INDEX

PARTNO.	GRID NO.	PARTNO.	GRID NO.	PARTNO.	GRID NO.	PARTNO.	GRID NO.	PARTNO.	GRID NO.	PARTNO.	GRID NO.
90105-065A1	C- 6	90179-10247	E- 8	90215-14204	B- 4	90450-28014	B- 9	91317-06050	C- 5	93306-00431	C- 9
90105-06553	C- 5	90179-16672	D- 13	90215-20231	C- 8	90450-57092	B- 13	91317-06060	C- 5	93306-07202	D- 15
	C- 10	90179-20001	C- 8	90215-21001	C- 8	90450-59091	B- 13	91317-06075	C- 5	93306-20335	B- 4
	C- 15		C- 10		C- 10	90460-15126	E- 10	91317-08020	C- 4	93306-20532	C- 9
90105-06690	C- 15	90179-28650	D- 7	90240-08120	E- 6	90460-61162	B- 13	91401-20012	E- 6	93306-20593	C- 9
90105-067A6	B- 2	90183-06023	B- 13	90240-10142	E- 6	90461-10136	C- 5	91401-25015	E- 6	93306-27205	D- 15
90105-08099	C- 13		C- 15	90267-32070	B- 13	90462-10241	C- 6	91808-16023	B- 2	93306-30633	B- 4
90105-08659	D- 14	90185-08169	C- 13	90267-48121	C- 4	90464-13073	E- 10	91812-16001	C- 6	93306-90403	D- 13
90105-08752	C- 7		E- 2	90280-03017	B- 4	90464-13077	E- 10	92014-06016	E- 7	93306-90501	C- 11
90105-10323	D- 5	90185-14112	D- 4	90282-05058	B- 4	90464-15152	E- 10	92017-08055	C- 13	93310-634B0	B- 4
90105-104A7	B- 2	90185-16127	D- 3	90338-16148	C- 13	90464-15195	E- 10	92907-06100	D- 12	93311-62574	B- 4
90105-105A2	D- 6	90185-20168	E- 2		D- 3	90464-16061	E- 10	92907-06600	B- 7	93315-11206	C- 8
90105-106A3	B- 2	90201-03313	B- 13	90340-12059	C- 5	90465-13152	E- 10	92907-08200	D- 14	93315-32056	D- 3
90105-10733	C- 13	90201-06071	B- 9	90340-12112	B- 2	90465-13275	E- 10	93101-14164	C- 6		D- 4
90109-06027	E- 9	90201-06557	C- 15	90340-14128	C- 6	90465-16258	E- 5	93102-12106	B- 8	93317-22262	D- 3
90109-063F8	C- 11	90201-08089	E- 6	90340-32123	C- 6	90467-09006	B- 9		C- 12	93332-00068	D- 7
90109-06418	B- 7	90201-081R9	C- 4	90387-06009	C- 15	90467-10008	D- 11	93102-12224	B- 7	93332-00081	D- 7
90109-065G2	B- 12	90201-08326	E- 2	90387-0614M	B- 9	90467-11106	B- 3		C- 8	93340-21505	C- 8
90109-065G4	E- 3	90201-08410	C- 3	90387-0701A	C- 15	90467-12085	E- 7	93102-20108	C- 7	93342-22217	D- 3
90109-066F0	B- 2	90201-08512	B- 8	90387-0814J	C- 4	90467-14015	B- 3	93102-26468	D- 13	93410-20038	C- 7
90109-081G1	E- 2	90201-086P8	C- 13	90387-086N4	C- 13	90467-17089	B- 13	93102-32480	C- 9	93420-19084	B- 4
90109-142F4	D- 4	90201-087A9	C- 7	90387-124F4	C- 12	90468-16191	E- 6	93106-22019	D- 3	93440-10085	B- 10
90109-147F2	D- 4	90201-101A4	B- 2	90387-164N2	D- 3	90480-08608	E- 2	93106-30044	D- 15		C- 8
90110-08096	C- 13	90201-101J1	E- 8	90387-164N3	D- 3	90480-15528	B- 9	93106-30045	D- 15	93440-10153	B- 2
90119-05071	D- 7	90201-10118	E- 5	90387-167Y9	D- 3	90480-18549	D- 11	93109-11073	B- 8	93440-25084	C- 9
90119-06096	C- 15		E- 7	90387-1712Y	C- 5	90501-043E0	C- 6	93109-20076	D- 3	93440-28062	C- 9
90119-06214	D- 11	90201-10119	E- 6	90387-1714R	D- 3	90501-052G5	C- 12		D- 4	93440-41178	B- 7
90119-08238	D- 2	90201-112U6	D- 6	90387-1714S	D- 3	90501-06022	C- 11	93109-28043	D- 3	93501-04011	C- 7
90122-06035	B- 13	90201-12166	B- 10	90387-2113G	C- 9	90501-13720	C- 7	93210-07003	B- 12	93503-08007	C- 6
90149-06011	D- 11	90201-125L6	C- 8	90387-225N2	E- 4	90501-16107	C- 7	93210-07135	B- 12	93603-17070	B- 10
90149-06250	B- 4	90201-14740	D- 4	90387-2513F	C- 9	90501-244L9	C- 9	93210-09008	B- 12	93604-10011	B- 8
90149-06324	E- 8	90201-15701	C- 6	90401-08038	B- 12	90508-16500	E- 6	93210-10197	B- 10	93608-33046	C- 12
90149-06326	C- 5	90201-162H4	C- 7	90401-10159	B- 12	90508-142B5	C- 8		C- 5	93612-16254	B- 3
90149-06327	D- 14	90201-164H4	D- 3	90401-10172	E- 5	90508-162B2	B- 7	93210-11073	E- 6	9383E-14215	C- 10
90151-04048	D- 3		D- 4		E- 7	90508-26561	C- 11	93210-12759	B- 12	94108-21008	D- 13
90151-06002	C- 5	90201-167P7	C- 7	90430-06014	B- 7	90508-282B8	E- 6	93210-14369	C- 6	94108-2110Y	D- 13
90152-06010	C- 7	90201-20276	C- 7		B- 8	90508-282B9	E- 6	93210-15620	E- 7	94108-2112Y	D- 13
90154-05073	E- 10	90201-203U1	E- 2	90430-08119	B- 12	90508-291A8	C- 12	93210-16500	B- 9	94111-19008	D- 15
90159-06078	D- 2	90201-20685	C- 7		C- 13	90508-30743	C- 7	93210-19123	C- 14	94111-1911B	D- 15
90159-06092	C- 8	90201-247L2	D- 7	90430-10188	B- 12	91A20-05065	B- 9	93210-19216	C- 7	94111-1913A	D- 15
90159-06182	D- 2	90201-253K0	C- 9	90430-12213	C- 5	91314-06030	B- 10	93210-19758	B- 8	94209-21229	D- 13
90170-14171	B- 4	90201-286K9	D- 7	90430-18130	C- 13	91316-04008	B- 14	93210-21276	E- 10	94211-19273	D- 15
90170-20327	C- 8	90202-05193	D- 11	90445-09100	D- 11	91316-04012	B- 14	93210-22298	C- 9	94211-19274	D- 15
90170-24373	D- 7	90202-08045	B- 14	90445-09220	D- 11	91317-05014	B- 13	93210-32172	C- 6	94227-21101	D- 13
90179-06500	B- 3	90206-06090	C- 4	90445-11002	D- 11	91317-06014	E- 5	93210-50553	B- 12	94309-21161	D- 13
90179-06568	D- 3	90209-06096	B- 13	90445-112K0	B- 3	91317-06016	E- 10	93300-60804	C- 13	94311-19155	D- 15
90179-08270	B- 3	90209-21332	C- 9	90450-22017	B- 10	91317-06025	B- 10	93306-00105	B- 8	94321-19157	D- 15
90179-08299	E- 2	90209-26348	C- 9	90450-25037	B- 9	91317-06040	C- 5	93306-00426	C- 9	94330-21084	D- 13

NUMERICAL INDEX

PARTNO.	GRID NO.	PARTNO.	GRID NO.	PARTNO.	GRID NO.	PARTNO.	GRID NO.	PARTNO.	GRID NO.
94416-21613	D - 13	95607-10200	C - 13						
94421-19602	D - 15		D - 5						
94581-68114	E - 2	95617-06635	B - 2						
94591-50120	B - 7	95617-08620	B - 2						
94681-68001	E - 2	95617-08635	B - 2						
94701-00318	B - 2	95617-14100	D - 4						
94701-00319	B - 2	95707-08500	B - 2						
94701-00329	B - 2		C - 13						
94701-00330	B - 2	95817-08012	C - 4						
94703-00318	B - 2	95817-08030	C - 4						
94703-00319	B - 2	95817-10050	C - 13						
94703-00329	B - 2	95817-10160	C - 13						
94703-00330	B - 2	95827-06010	B - 9						
95021-08040	D - 9	95827-06012	D - 14						
95024-08020	B - 11	95827-06014	B - 7						
95027-06010	C - 8	95827-06016	D - 2						
	D - 3	95827-08012	C - 13						
95027-06012	B - 9	95827-08016	C - 14						
	B - 12	97007-05016	E - 9						
	B - 13	97007-06012	D - 12						
	E - 3	97027-06016	B - 7						
	E - 7	97707-60016	C - 15						
95027-06014	D - 7	97780-50510	E - 7						
95027-06016	D - 11	97801-03008	D - 11						
	E - 3	98507-05008	D - 3						
95027-06020	B - 12	98507-05020	E - 4						
	C - 12	98507-06025	C - 5						
95027-06025	B - 7	98706-04012	E - 5						
	B - 8	98706-04040	E - 7						
	B - 9	98707-06025	D - 11						
	B - 10	98907-05020	E - 9						
	B - 11	98907-06020	D - 11						
95027-06030	C - 6	98980-06008	C - 4						
95027-06040	B - 3	99001-08600	B - 10						
	C - 6	99009-12400	B - 10						
95027-06050	D - 3	99009-16400	C - 7						
95027-06065	B - 12	99009-20400	C - 7						
95027-08012	C - 14	99009-22500	C - 6						
95027-08020	D - 14	99009-45500	D - 15						
95027-08035	D - 7	99241-00080	C - 15						
95027-08040	C - 13	99244-00200	D - 4						
	D - 7	99530-08012	B - 10						
95027-08065	C - 13	99530-08016	C - 6						
95301-08700	E - 7	99530-10114	B - 10						
95606-06100	E - 5		C - 5						
95607-05100	B - 13	99530-10116	C - 5						
	E - 9	99530-14016	C - 5						
95607-06100	E - 9								